

Multistandard TV Audio Processor and Digital Sound Demodulator

DATASHEET

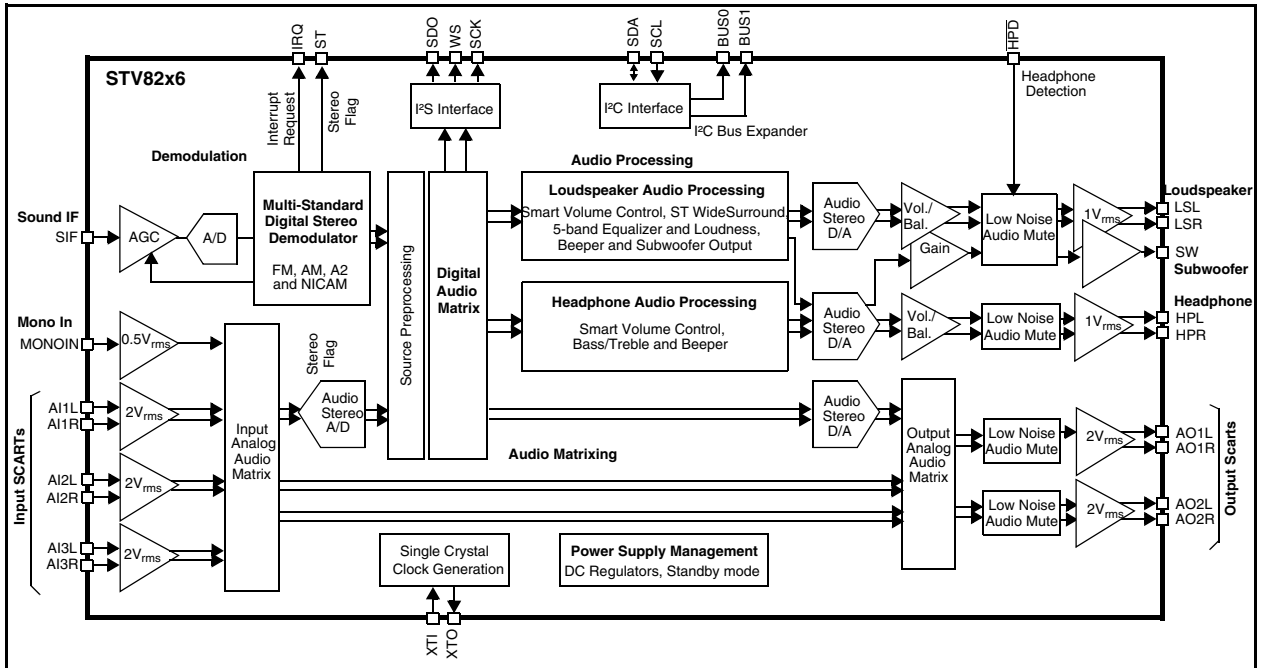

This device incorporates the SRS (Sound Retrieval System) under licence from SRS Labs, Inc.

- Subwoofer output with Volume Control and Programmable Bandwidth
- Spatial Sound Effects (ST WideSurround and Pseudo-Stereo)



Key Features

- NICAM, AM, FM Mono and FM 2 Carrier Stereo Demodulators for all sound carriers between 4.5 and 7 MHz
- Mono input provided for optimum AM Demodulation performances
- Demodulation controlled by Automatic Standard Recognition System
- Sound IF AGC with wide range
- Overmodulation and Carrier Offset recovery
- Smart Volume Control
- 5-band Equalizer & Bass/Treble Control
- Automatic Loudness Control
- Loudspeaker and Headphone outputs with Volume/Balance Controls and Beeper
- SRS® 3D Surround
- 3-to-2 Analog Stereo Audio I/Os (SCART compatible) with Audio Matrix
- Low-noise Audio Mutes and Switches
- I2S Output to interface with Dolby® Pro Logic® Decoder
- I2C Bus-controlled
- Single and standard 27 MHz Crystal Oscillator
- Power supplies: 3.3 V Digital, 5 V or 8 V Analog
- Embedded 3.3 V Regulators
- Packages: SDIP56 or TQFP80

Table of Contents

Chapter 1	General Description	5
1.1	Overview	5
1.2	Typical Applications	6
1.3	I/O Pin Description	10
Chapter 2	Demodulator Block	12
2.1	Digital Demodulator	12
2.2	System Clock	16
Chapter 3	Audio Processor Block	17
3.1	Main Features	17
3.2	Smart Volume Control (SVC)	18
3.3	ST WideSurround	19
3.4	5-Band Audio Equalizer	19
3.5	Bass/Treble Control	19
3.6	Volume/Balance Control	20
3.7	Automatic Loudness Control	22
3.8	Subwoofer Control	22
3.9	Beeper	22
3.10	SRS™ 3D Surround (STV8226/36 only)	23
Chapter 4	Audio Matrices	25
4.1	Input Audio Matrix	26
4.2	Output Audio Matrix	26
Chapter 5	Additional Controls and Flags	27
5.1	Interrupt Request	27
5.2	I ² C Bus Expander	27
5.3	Stereo Flag	27
5.4	Headphone Detection	27
Chapter 6	I²S Interface	28

Chapter 7	Power Supplies	29
7.1	Supply Voltages	29
7.2	Standby Mode	30
Chapter 8	I²C Bus	31
8.1	I ² C Address and Protocol	31
8.2	STV82x6 Reset	31
Chapter 9	Register List	33
9.1	I ² C Register Map	33
9.2	STV82x6 General Control Registers	37
9.3	Analog Block	39
9.4	Clocking	41
9.5	Demodulator	43
9.6	Demodulator Channel 1	46
9.7	Demodulator Channel 2	49
9.8	NICAM Registers	55
9.9	Zweiton	56
9.10	Sound Preprocessing and Selection Registers	57
9.11	Automatic Standard Recognition	64
9.12	Smart Volume Control	68
9.13	Surround	70
9.14	5- Band Equalizer	72
9.15	Loudness/Bass & Treble	74
9.16	Volume/Balance Control Registers	76
9.17	Subwoofer	79
9.18	Beeper	80
Chapter 10	Input/Output Groups	82
Chapter 11	Electrical Characteristics	86
11.1	Absolute Maximum Ratings	86
11.2	Thermal Data	86
11.3	Supply	86
11.4	Crystal Recommendations	87

11.5	Analog Sound IF Signal Recommendations	87
11.6	SIF to LS/HP/SCART Path Characteristics	88
11.7	SCART to SCART Analog Path Characteristics	88
11.8	SCART to I2S Output Path (via ADC) Characteristics	89
11.9	MONOIN to ADC and I2S Output Path Characteristics	89
11.10	I2S to LS/HP/SW Path Characteristics	89
11.11	I2S to SCART Path Characteristics	90
11.12	Loudspeaker and Headphone Volume Control Characteristics	90
11.13	MUTE Performance	90
11.14	Digital I/Os	90
11.15	I ² C Bus Interface	91
Chapter 12	Package Mechanical Data	93
Chapter 13	Revision History	95

1 General Description

1.1 Overview

The STV82x6 is composed of three main parts:

1. **TV Sound Demodulator:** provides all the necessary circuitry for the demodulation of audio transmissions of European and Asian terrestrial TV broadcasts. The various transmission standards are automatically detected and demodulated without user intervention.
2. **Audio Processor:** based on DSP technology, independently controls loudspeaker, subwoofer and headphone signals. It offers basic and advanced features, such as a ST WideSurround, Equalizer, Automatic Loudness and Smart Volume Control for television viewer comfort. The STV8226/36 versions can perform additionally the SRS® 3D Surround for stereo and mono signals.
3. **Audio Matrix:** 3 stereo and 1 mono external analog audio inputs to loudspeakers and headphone, with 2 stereo external analog audio outputs (SCART compatible).

Table 1: STV82x6 Version List

Feature	STV8206	STV8216	STV8226	STV8236
AM-FM Mono	X	X	X	X
Zweiton	X	X	X	X
NICAM		X		X
ST WideSurround	X	X	X	X
SRS® 3D Surround			X	X

Figure 1: Package Ordering Information

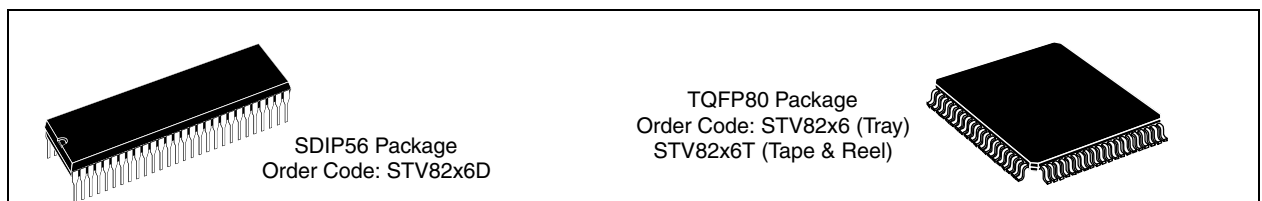

1.2 Typical Applications

Figure 2: Typical Application (Low-cost Stereo TV)

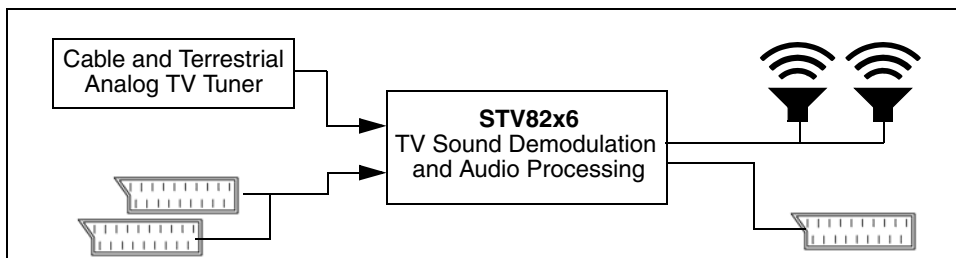

Figure 3: Typical Application with Subwoofer and Headphone

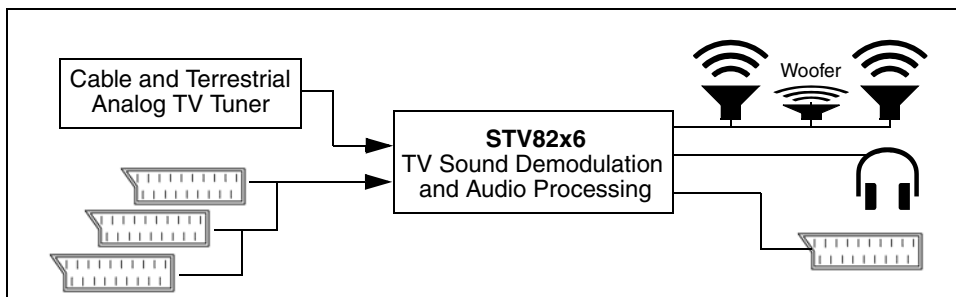

Figure 4: Typical Application Electrical Diagram for STV82x6 in SDIP56 package

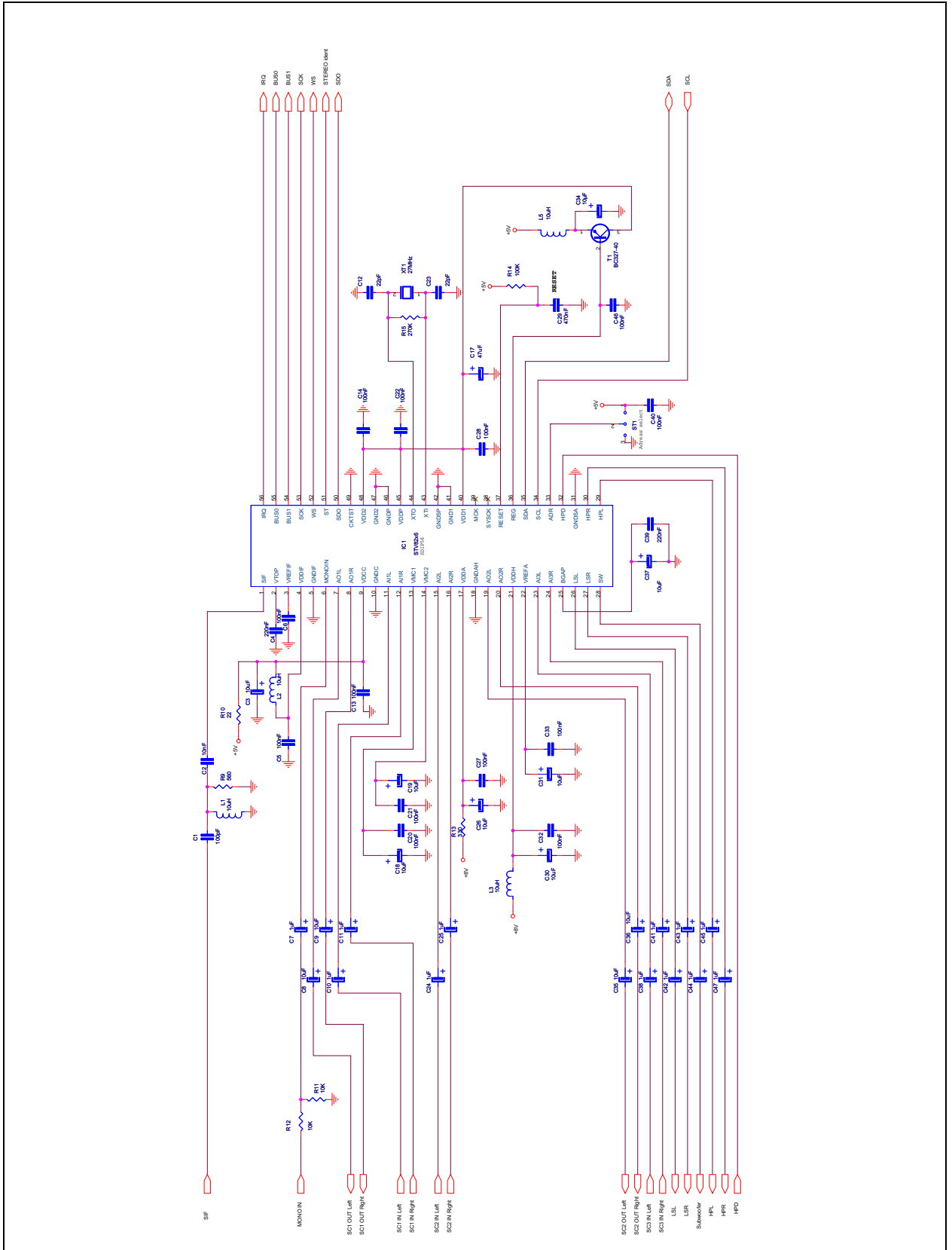

Figure 5: Typical Application Electrical Diagram for STV82x6 in TQFP80 package

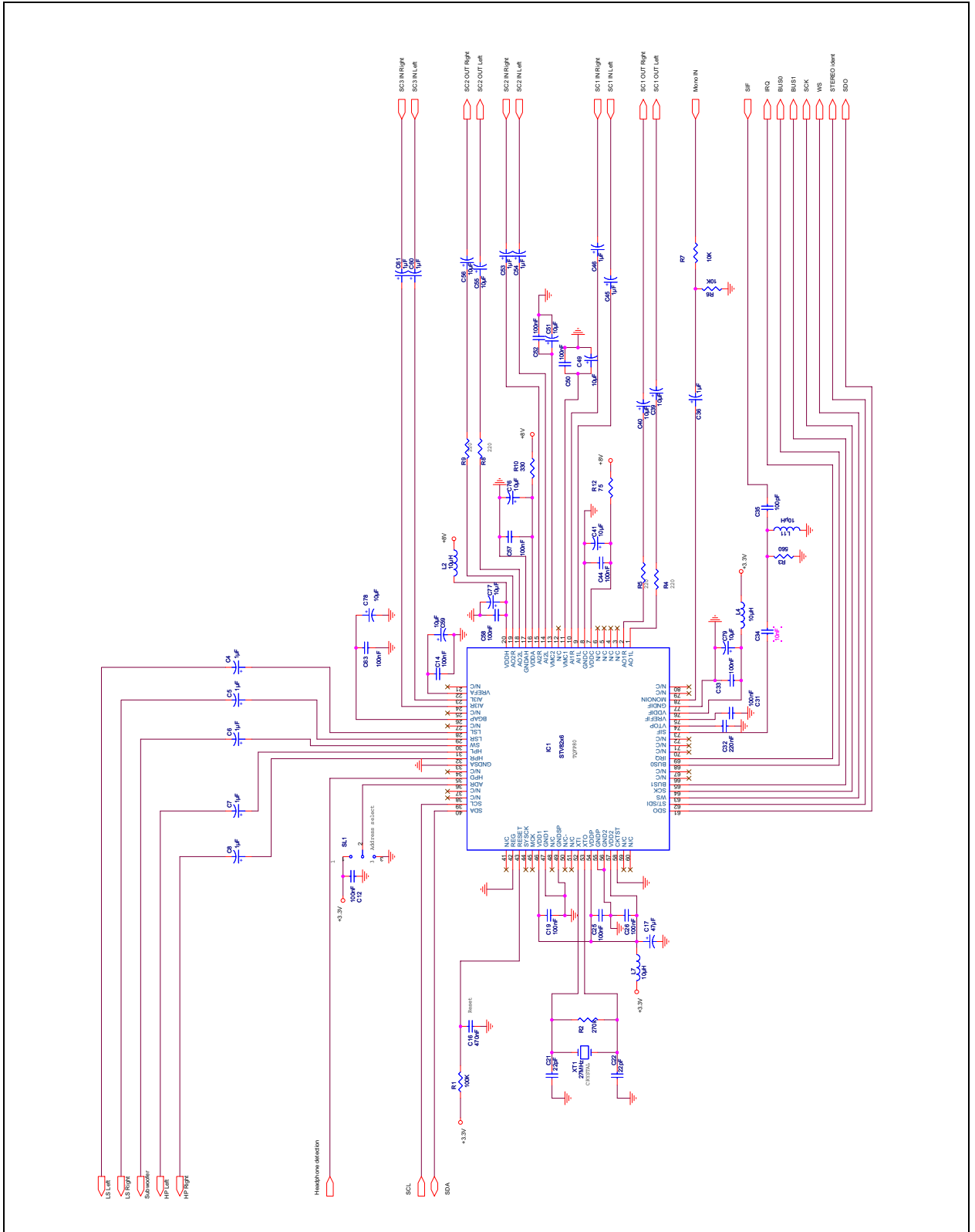
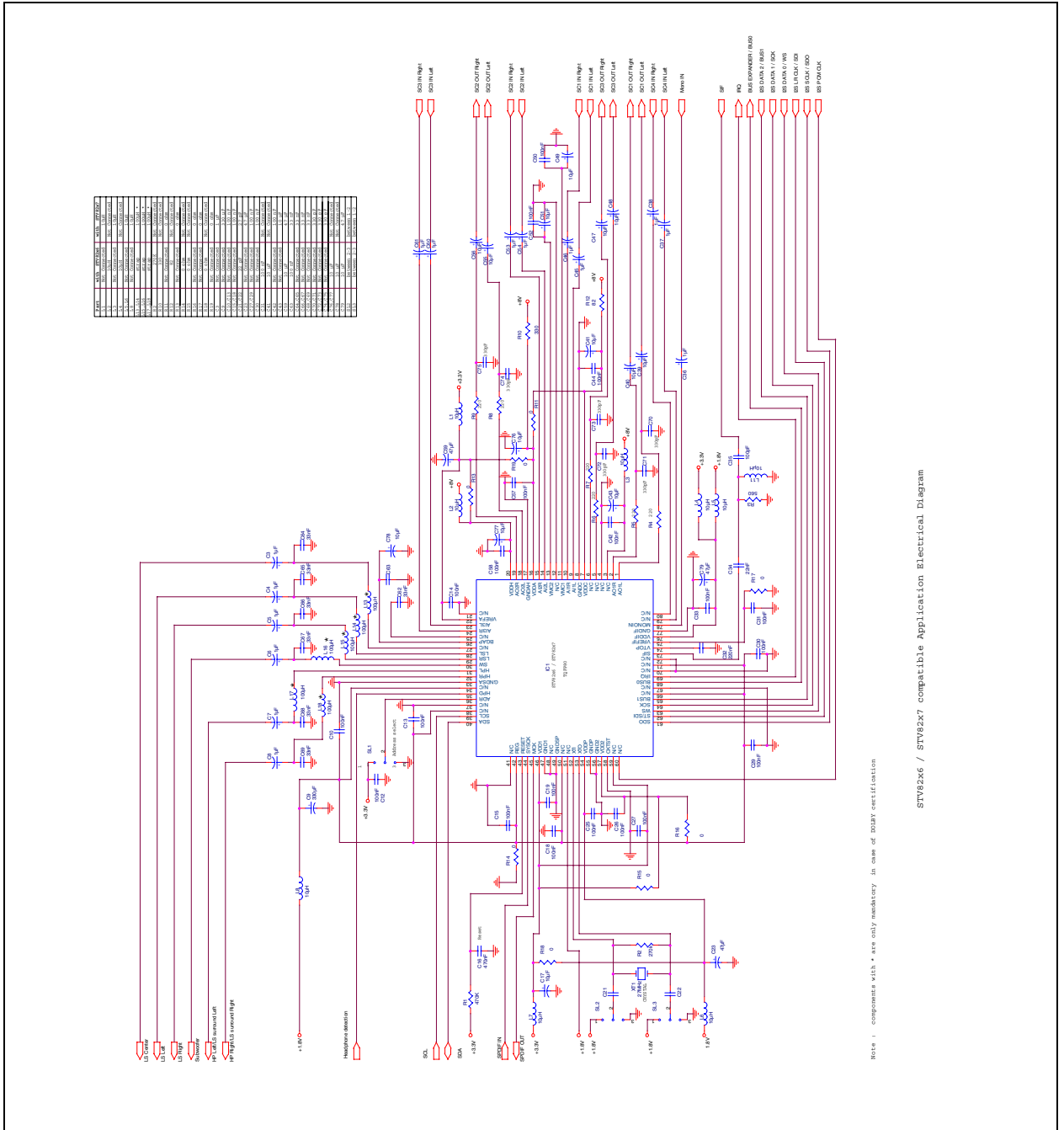

Figure 6: Typical Compatible Application Electrical Diagram for STV82x6 and STV82x7 in TQFP80 package



Note : components with * are only mandatory in case of RoHS certification

STV82x6 / STV82x7 compatible Application Electrical Diagram

1.3 I/O Pin Description

Legend / Abbreviations for [Table 2](#):

Type:

- AP = Analog Power Supply
- DP = Digital Power Supply
- I = Input
- O = Output
- OD = Open Drain
- B = Bidirectional
- A = Analog

Table 2: Pin Description

SDIP 56	TQFP 80	Name	Type	Function
1	73	SIF	A	Sound IF Input
2	74	VTOP	A	ADC V_{TOP} Decoupling Pin
3	75	VREFIF	A	AGC Voltage Reference Decoupling Pin
4	76	VDDIF	AP	3.3 V Power Supply for IF AGC & ADC
5	77	GNDIF	AP	0 V Power Supply for IF AGC & ADC
6	78	MONOIN	A	Mono Input
	79/80	N/C		Not Used
7	1	AO1L	A	Left SCART1 Audio Output
8	2	AO1R	A	Right SCART1 Audio Output
-	3/4/5/6	N/C		Not used
9	7	VDDC	AP	3.3 V Power Supply for Audio DAC/ADC
10	8	GNDC	AP	0 V Power Supply for DAC/ADC
11	9	AI1L	A	Left SCART1 Audio Input
12	10	AI1R	A	Right SCART1 Audio Input
13	11	VMC1	A	Switched V_{REF} Decoupling Pin for Audio Converters (VMCP)
-	12	N/C		Not used
14	13	VMC2	A	V_{REF} Decoupling Pin for Audio Converters (VMC)
15	14	AI2L	A	Left SCART2 Audio Input
16	15	AI2R	A	Right SCART2 Audio Input
17	16	VDDA	AP	3.3 V Power Supply for Audio Buffers, Matrix & Bias
18	17	GNDAH	AP	0 V Power Supply for Audio Buffers & SCART
19	18	AO2L	A	Left SCART2 Audio Output
20	19	AO2R	A	Right SCART2 Audio Output
21	20	VDDH	AP	8 V / 5 V Power Supply for SCART & Audio Buffers
-	21	N/C		Not Used
22	22	VREFA	A	Voltage Reference for Audio Buffers
23	23	AI3L	A	Left SCART3 Audio Input
24	24	AI3R	A	Right SCART3 Audio Input
-	25	N/C		Not Used
25	26	BGAP	A	Bandgap Voltage Source Decoupling

Table 2: Pin Description (Continued)

SDIP 56	TQFP 80	Name	Type	Function
-	27	N/C		Not Used
26	28	LSL	A	Left Loudspeaker Output
27	29	LSR	A	Right Loudspeaker Output
28	30	SW	A	Subwoofer Output
29	31	HPL	A	Left Headphone Output
30	32	HPR	A	Right Headphone Output
31	33	GNDSA	AP	Substrate Analog/Digital Shield
-	34	N/C		Not Used
32	35	HPD	B	Headphone Detection Input (Active Low)
33	36	ADR	I	Hardware I ² C Chip Address Control
-	37/38	N/C		Not Used
34	39	SCL	OD	I ² C Serial Clock
35	40	SDA	OD	I ² C Serial Data
-	41	N/C		Not Used
36	42	REG	A	5 V Power Regulator Control
37	43	RESET	I	Hardware Reset (Active Low)
38	44	SYSCK	B	System Clock Output
39	45	MCK	B	I ² S Master Clock Output
40	46	VDD1	DP	3.3V Power Supply for Digital Core & IO Cells
41	47	GND1	DP	0V Power Supply for Digital Core & IO Cells
-	48	N/C		Not Used
42	49	GNDSP	AP	Substrate Analog/Digital Shield for Clock-PLL
	50/51	N/C		Not Used
43	52	XTI	I	Crystal Oscillator Input
44	53	XTO	O	Crystal Oscillator Output
45	54	VDDP	AP	3.3 V Power Supply for Analog PLL Clock
46	55	GNDP	AP	0 V Power Supply for Analog PLL Clock
47	56	GND2	DP	0 V Power Supply for Digital Core, DSPs & IO Cells
48	57	VDD2	DP	3.3 V Power Supply for Digital Core, DSPs & IO Cells
49	58	CKTST	I	Must be Connected to 0 V
-	59/60	N/C		Not Used
50	61	SDO	B	I ² S Bus Data Output
51	62	ST/SDI	B	Stereo Detection Output / I ² S Bus Data Input
52	63	WS	B	I ² S Bus Word Select Output
53	64	SCK	B	I ² S Bus Clock Output
54	65	BUS1	B	I ² C Bus Expander Output 1
-	66/67	N/C		Not Used
55	68	BUS0	B	I ² C Bus Expander Output 2
56	69	IRQ	B	I ² C Status Read Request
-	70	N/C		Not Used
-	71	N/C		Not Used
-	72	N/C		Not Used

2 Demodulator Block

Figure 7: Demodulator Block Diagram

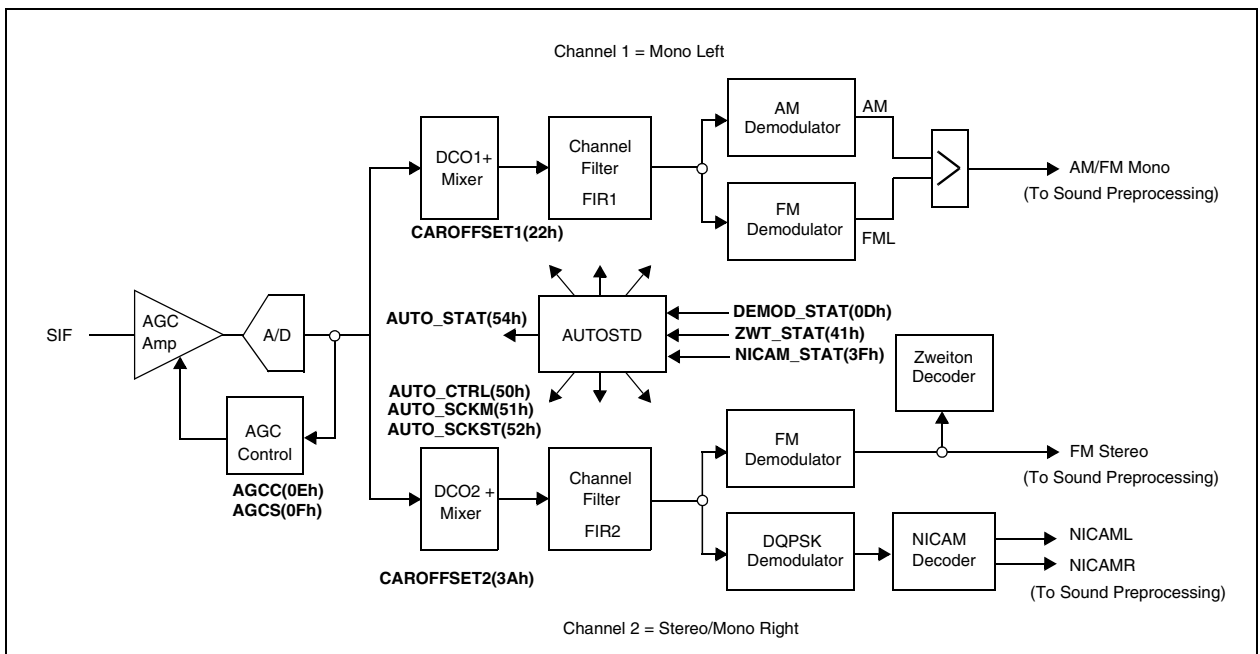

Note: *Zweiton is the Dual (Two Tone) FM stereo or A2 system.*

2.1 Digital Demodulator

2.1.1 Sound IF Signal

The Analog Sound Carrier IF is connected to STV82x6 via the SIF pin. Before Analog-to-Digital Conversion (ADC), an Automatic Gain Control (AGC) is performed to adjust the incoming IF signal to the full scale of the ADC. A preliminary video rejection is recommended to optimize conversion and demodulation performances. The AGC system provides a wide range of SIF input levels and is activated for all standards, except L/L'. In this particular case, the sound carrier is AM-modulated and an automatic level adjustment would only damage transmitted audio signal. A preset I²C parameter is required to define the gain of the AGC used in Manual mode (Registers [AGCC](#) and [AGCS](#)).

2.1.2 Demodulation

The demodulation system operates by default in Automatic mode. In this mode, the STV82x6 is able to **identify and demodulate any TV sound standard including NICAM and A2 systems** (see [Table 2](#)) without any external control via the I²C interface. It consists of the two demodulation channels (Channel 1 = Mono Left and Channel 2 = Mono Right/Stereo) to simultaneously process two sound carriers in order to handle all transmission modes (stereo and up to three mono languages). The **built-in Automatic Standard Recognition System (AUTOSTD)** automatically programs the appropriate bits in the I²C registers which are forced to Read-only mode for users (see [Section 9.1](#)). The programming is optimized for each standard to be identified and demodulated.

Each mono and stereo standard can be removed (or added) from the List of Standards to be recognized by programming registers [AUTO_SCKM](#) and [AUTO_SCKST](#), respectively. The identified standard is displayed in register [AUTO_STAT](#) and any change to standard is flagged to the host system via pin IRQ. This flag must be reset by re-programming the MSBs of register [AUTO_CTRL](#) while checking the detected standard status by reading registers [AUTO_STAT](#), [NICAM_STAT](#) and [ZWT_STAT](#). Moreover, the detection of Stereo mode during demodulation is also flagged in register [AUTO_STAT](#) and on output pin ST.

Important: L/L' and D/K standards cannot be automatically processed because the same frequency is used for the MONO carrier. An exclusive L/DK selection must be programmed in register [AUTO_CTRL](#). This may be externally controlled by detecting the RF modulation sign, which is negative for all TV standards except L/L'.

To recover out-of standard FM deviations or the Sound Carrier Frequency Offset, additional I²C controls are provided without interfering with the Automatic Standard Recognition System (AUTOSTD).

DK-NICAM Overmodulation Recovery: Four different FM deviation ranges can be selected (via register [AUTO_CTRL](#)) for the DK standard while the AUTOSTD system remains active. The maximum FM deviation is 500 kHz in DK Mono mode and 350 kHz in DK NICAM mode (limited by overlapping FM and NICAM spectrum values). The demodulated signal peak level (proportional to the FM deviation) is detected by the Peak Detector and written to registers [PEAK_DET_STATL](#) and [PEAK_DET_STATR](#). This value is used to implement Automatic Overmodulation Detection via an external I²C control.

Important: Only the selection of the 50 kHz FM deviation standard is compatible with the other DK-A2* standards (DK1, DK2 or DK3). These standards must be removed from the list of standards (registers [AUTO_SCKM](#) and [AUTO_SCKST](#)) when programming larger FM deviations reserved only for DK-NICAM standards.

Table 3: Standards covered by the Automatic Standard Recognition System (AUTOSTD)

System	Sound Type	Type Name	Carrier 1 (MHz)	Carrier 2 (MHz)	FM/AM Deviation			De-emphasis	Roll-off (%)	Pilot Frequency (kHz)	
					Min.	Typ.	Max.				
M/N	FM Mono		4.5		15	27	50	75 µs		55.069	
	FM 2 Carriers	A2+		4.724							
B/G	FM Mono		5.5		27	50	80	50 µs			
	FM/NICAM			5.850				J17			40
	FM 2 Carriers	A2		5.742				50 µs			54.6875
I	FM Mono		6.0		27	50	80	50 µs	100		
	FM/NICAM			6.552				J17			100
L	AM Mono		6.5		0.5		1.0		40		
	AM/NICAM			5.850				J17			
D/K	FM Mono					27	50	80	50 µs	40	
	FM/NICAM			5.850	J17						
D/K1	FM 2 Carriers	A2*		6.258	27	50	80	50 µs		40	54.6875
D/K2	FM 2 Carriers			6.742							
D/K3	FM 2 Carriers		5.742								

Sound Carrier Frequency Offset Recovery: Both Mono and Stereo IF Carrier frequencies can be adjusted independently (registers [CAROFFSET1](#) and [CAROFFSET2](#)) within a large range (up to 120 kHz for standard mono FM deviations) while the AUTOSTD system remains active. The frequency offset estimation is written in registers [FM_DCL](#) and [FM_DCR](#) (Mono Left / Channel 1 And Mono Right / Channel 2, respectively) and can be used to implement the Automatic Frequency Control (AFC) via an external I²C control.

If required, the AUTOSTD system can be disabled (Manual mode) and the user can control all registers including those only controlled by the AUTOSTD function when active. Manual mode is selected in registers [RESET](#) or [AUTO_SCKM](#).

2.1.3 Sound Preprocessing and Selection

The demodulated sound signal can be redirected to 4 different output audio channels:

1. Loudspeaker & Subwoofer,
2. Headphone,
3. SCART,
4. I²S Interface.

Each output channel can independently select the demodulator source, analog SCART or I²S inputs using register [CH_SEL](#).

Figure 8: Sound Preprocessing and Selection Block Diagram

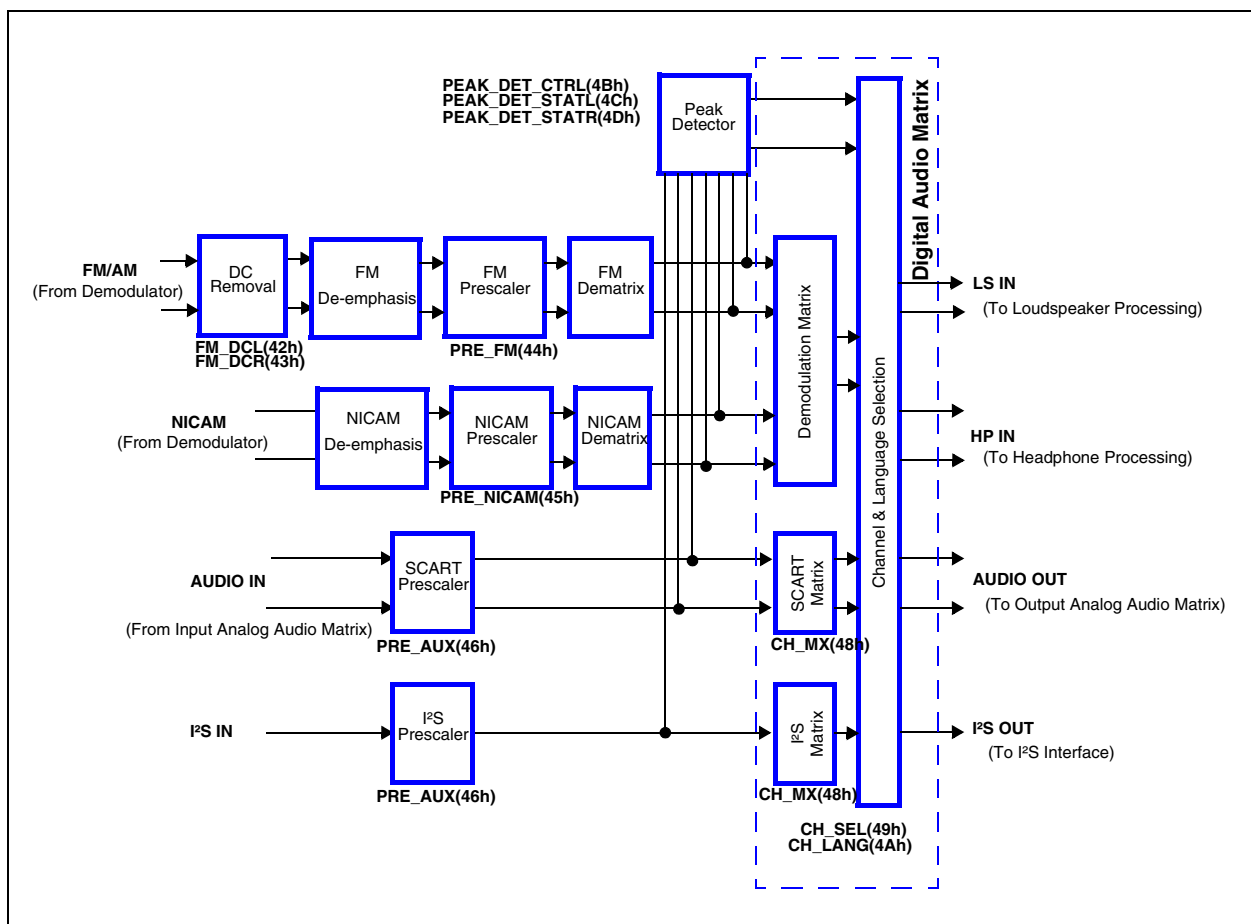

The level of the demodulated sound may require adjusting in order to compensate for the difference in levels between the multiple source (NICAM, FM or AM) and standard source (FM deviation wide range from 15 to 500 kHz) signals. The correct range for all level variations (+24 to -6 dB) is selected in registers [PRE_FM](#) and [PRE_NICAM](#). The internal sound level of the various sources (FM/AM, NICAM and SCART) is read in registers [PEAK_DET_CTRL](#), [PEAK_DET_STATL](#) and [PEAK_DET_STATR](#) before audio processing and can be used to implement Automatic Pre-scaling via an external I²C interface.

In Automatic mode, the STV82x6 selects and performs all appropriate de-emphasis, dematrixing, sound selection and mute functions according to the standard and transmission mode detected.

Mono system: Mono audio signals received by an FM or AM carrier are demodulated. Left and right audio outputs are identical. Automatic mute is applied when the mono standard cannot be identified.

A2 systems (or Zweiton): Transmission of mono, stereo or bilingual audio signals using 2 separate FM carriers + identification pilot. The pilot, transmitted by the second carrier, can be modulated by two different tones in order to define Stereo or Dual-Mono mode. If not modulated, only the mono signal is broadcast on the first carrier. Zweiton mode is read in register [ZWT_STAT](#) and described in [Table 4](#). In the event of poor signal detection, the audio output is switched back to FM Mono mode (backup). In Dual Mono mode, the language (A on Channel 1, B on Channel 2) can be selected separately for each audio output channel (Loudspeaker, Headphone, SCART or I²S) in register [CH_LANG](#).

Table 4: A2 System Transmission Modes

System Mode	ZWT-STAT [2:0]	FM Dematrix	FM De-emphasis	CH_LANG [1:0]	Sound Selection	Sound Backup
German Zweiton Mono	100	L,R	50 µs	XX	FM Mono	X
German Zweiton Stereo	110	(L+R)/2,R	50 µs	XX	FM Stereo	FM Mono
German Zweiton Dual Mono (CH1=A, CH2=B)	101	L,R	50 µs	01	FM Mono A	X
				10	FM Mono B	Mute
Korean Zweiton Mono	100	L,R	75 µs	XX	FM Mono	X
Korean Zweiton Stereo	110	(L+R)/2,(L-R)/2	75 µs	XX	FM Stereo	FM Mono
Korean Zweiton Dual Mono (CH1 = A, CH2 = B)	101	L,R	75 µs	01	FM Mono A	X
				10	FM Mono B	Mute
Zweiton undefined	0XX or 111	L,R	50 µs	XX	FM Mono	X

Note: A2 and A2 standards are German Zweiton, while A2+ is Korean Zweiton.*

NICAM systems: Transmission of mono, stereo, bilingual or trilingual audio signals using a modulated-QPSK carrier and an FM/AM sound carrier backup. The digital QPSK modulation broadcasts either channel stereo, dual mono, mono + data or data only. The selected NICAM mode is read in register [NICAM_STAT](#) and described in [Table 5](#). In the event of high bit-error rates, the audio output is automatically switched back to the reserve sound transmission (FM/AM Mono) or muted if there is no backup. In Dual Mono or Stereo mode with no backup, the language can be selected separately for each audio output channel (Loudspeaker, Headphone, SCART or I²S) in register [CH_LANG](#).

Table 5: NICAM System Transmission Modes

System Mode	NICAM_STAT[4:1]	NICAM De-emphasis	CH_LANG[1:0]	Sound Selection	Sound Backup
NICAM Stereo	1000	J17	XX	NICAM Stereo	FM/AM Mono
NICAM Dual Mono (CH1 = A, CH2 = B)	1010	J17	01	NICAM Mono A	FM/AM Mono
			10	NICAM Mono B	Mute
NICAM Mono+Data (D1 = A, D2 = Data)	1001	J17	XX	NICAM Mono A	FM/AM Mono
NICAM Data	1011	J17	XX	FM/AM Mono	X
NICAM Stereo (no backup)	0000	J17	01	FM/AM Mono A	X
			00	NICAM Stereo	Mute
NICAM Dual Mono (no backup) (D1 = B, D2 = C)	0010	J17	01	FM/AM Mono A	X
			10	NICAM Mono B	Mute
			11	NICAM Mono C	
NICAM Mono+Data (no backup) (D1 = B, D2 = Data)	0001	J17	01	FM/AM Mono A	X
			10	NICAM Mono B	Mute
NICAM undefined (no backup)	X1XX	J17	XX	FM/AM Mono	X

Note: D1 and D2 define the two channels encoded in the NICAM packet.

2.2 System Clock

The System Clock integrates a low-jitter PLL clock and can be fully reprogrammed via registers [PLL_DIV](#), [PLL_MD](#), [PLL_PEH](#) and [PLL_PEL](#). The default values are designed for a **standard 27-MHz quartz crystal frequency**, which is the recommended frequency for minimizing potential RF interference in the application. This sinusoidal clock frequency, and any harmonic products, remains outside the TV picture and sound IF (PIF/SIF) and Band-I RF passbands and has been selected in order to reduce the risk of potential interference to the TV IF and RF system.

However, if required, the PLL clock can be re-programmed for an other quartz crystal frequency within a range between 23 and 30 MHz.

Note: A change in the crystal frequency is compatible with other default I²C programming values, including those of the built-in Automatic Standard Recognition System.

3 Audio Processor Block

3.1 Main Features

The STV82x6 Audio Processor is based on a dedicated audio Digital Signal Processor (DSP) that performs basic and advanced audio post-processing for 4 different output audio channels.

3.1.1 Loudspeaker and Subwoofer Features

- Smart Volume Control (See [Note 1](#))
- Spatial effects:
 - Pseudo Stereo (for Mono source)
 - ST WideSurround (“Movie” and “Music” modes for Stereo source)
- 5-band Equalizer
- Volume and Balance controls (See [Note 4](#))
- Automatic Loudness control
- Subwoofer (See [Note 4](#))
- Beeper (See [Note 3](#))

Additionally on STV8226/36 only:

- SRS™ 3D Mono signal processing
- SRS™ 3D Stereo signal processing

3.1.2 Headphone (See [Note 2](#))

- Smart Volume Control (See [Note 1](#))
- Bass and Treble controls
- Volume and Balance controls
- Beeper (See [Note 3](#))

Note: 1 The Smart Volume Control can be used in either the loudspeaker or headphone path, but not both at the same time.

2 The headphone is forced into Mono mode when the subwoofer is active.

3 The beeper is common for both the loudspeaker and the headphone.

4 The Auto-mute function is activated when a headphone plug is detected.

5 All audio postprocessing can be disabled.

3.1.3 SCART 1 and 2 Outputs

- No audio post-processing

3.1.4 I²S Output

- No audio post-processing

Figure 9: Audio Processor Block Diagram

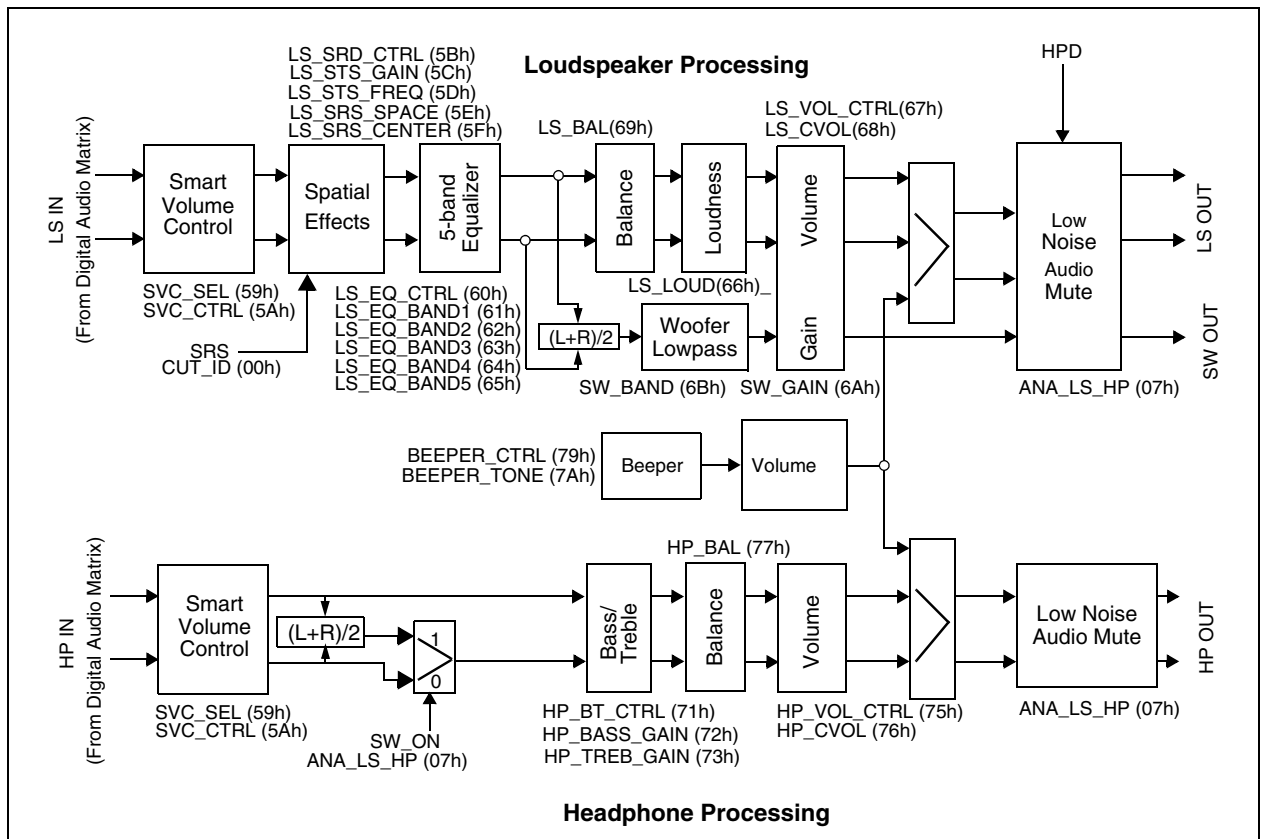

Note: The audio signals available on the I²S and SCART outputs are not affected by any digital or analog matrix processing.

3.2 Smart Volume Control (SVC)

The Smart Volume Control (SVC) feature is designed to process sound level variations caused by changes in signal sources (e.g. when switching channels) or in volume (e.g. when advertisements are broadcast). The SVC is controlled by the SVC_ON bit in the [SVC_CTRL](#) register.

When the SVC_ON bit is set, the Smart Volume Control prevents annoying volume changes by automatically adjusting the selected sound source (demodulator or SCART) to a programmable reference level before audio processing. The regulation ranges from +6 dB to -30 dB with a fast attenuation and a programmable slow amplification. The fast attenuation reduces audio peak (and potential clipping) and slow amplification is a compromise between regulation recovery and limited audio amplification during audio silence. The programmable output reference level must be defined to prevent internal clipping depending on the selected audio processing boosting functions such as Surround (up to +9 dB), Equalizer or Bass/Treble (up to +12 dB) and Loudness (up to +6 dB). When the SVC is enabled, recommended reference values are -18 dB for the Loudspeaker path and -9 dB for the Headphone path.

When the SVC is disabled, it acts as a wide-range prescaler (between -30 dB and +15.5 dB) before audio-processing to prevent internal clipping depending on the selected functions (see above). If

required, it complements the dedicated prescaler for FM, NICAM or SCART sources. The internal level can be measured using the peak detector.

The SVC can be used either in the Loudspeaker or Headphone path (but not both simultaneously). When used in the Headphone path, the SVC prevents the sound level from becoming suddenly too strong, causing ear damage. The SVC is configured in registers [SVC_SEL](#) and [SVC_CTRL](#).

3.3 ST WideSurround

STV82x6 offers three preset ST WideSurround effects on the Loudspeaker path:

- Music, a concert hall effect
- Movie, for films on TV
- Simulated Stereo, which generates a pseudo-stereo effect from mono source

“ST WideSurround” is an extension of the conventional stereo concept which improves the spatial characteristics of the sound. This could be done simply by adding more speakers and coding more channels into the source signal as is done in the cinema, but this approach is too costly for normal home use. The ST WideSurround system exploits a method of phase shifting to achieve a similar result using only two speakers. It restores spatiality by adding artificial phase differences.

The Surround/Pseudo-stereo mode is automatically selected by the Automatic Standard Recognition System (AUTOSTD) depending on the detected stereo or mono source. By default, “Movie” is selected for Surround mode. This value may be changed to “Music” by the STS_MODE bit in the [LS_SRD_CTRL](#) register.

Additional user controls are provided to better adapt the spatial effect to the source. The ST WideSurround Gain ([LS_STS_GAIN](#)) and ST WideSurround Frequency ([LS_STS_FREQ](#)) registers can be used to enhance music predominance in Music mode and theater effect + voice predominance in Movie mode.

3.4 5-Band Audio Equalizer

The Loudspeaker audio spectrum is split into 5 frequency bands and the gain of each of them can be adjusted within a range from -12 dB to +12 dB in steps of 1 dB. The Audio Equalizer may be used to pre-define frequency band enhancement features dedicated to various kinds of music or to attenuate frequency resonances of loudspeakers or the listening environment. The Equalizer is enabled by the EQ_ON bit in the [LS_EQ_CTRL](#) register. The Bass, Medium and Treble values are programmed in registers [LS_EQ_BAND\[1:5\]](#).

Figure 10: Equalizer

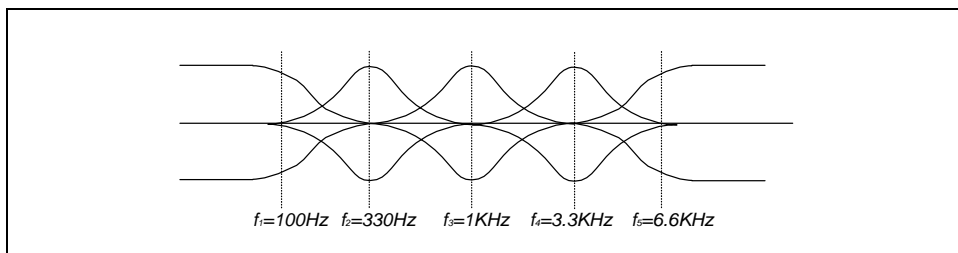

3.5 Bass/Treble Control

The gain of bass and treble frequency bands for the headphone can be also tuned within a range from -12 dB to +12 dB in steps of 1 dB. It may be used to pre-define frequency band enhancement

features dedicated to various kinds of music, to implement programmable Loudness or Super-bass functions. The Headphone Bass/Treble feature is enabled by setting the BT_ON bit in the [HP_BT_CTRL](#) register. The Bass and Treble gain values are adjusted in registers [HP_BASS_GAIN](#) and [HP_TREBLE_GAIN](#), respectively.

3.6 Volume/Balance Control

The STV82x6 provides a Volume/Balance Control for each of the Loudspeaker, Subwoofer and Headphone audio outputs. Its wide range (from 0 to -96 dB in a linear scale) largely covers typical home applications (approx. 60 dB) while maintaining a good S/N ratio. Its fine resolution (0.375 dB) provides simple volume programming and a relative OSD scale representation. The Loudspeaker, Subwoofer and Headphone volume values should be programmed progressively in steps of less than 1 dB in order to prevent audible envelope variations and a minimum duration of 16 ms is required between two successive programming commands to guarantee that there are no audible plops during volume changes. In this case, a full 8-bit volume scan with minimum steps of 0.375 dB will last approximately 4 s (minimum).

Figure 11: Volume Control

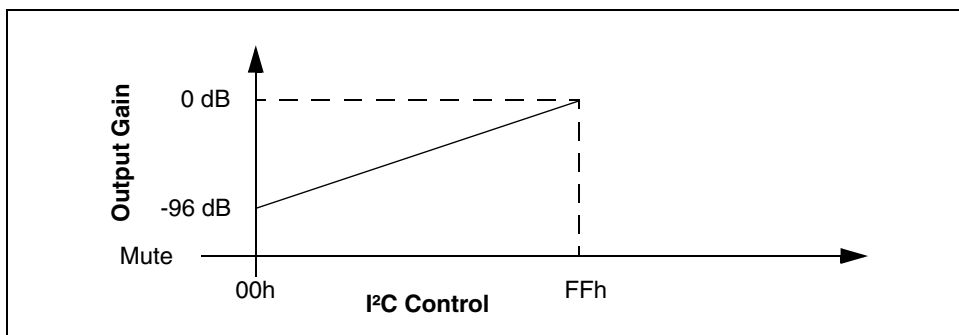

The Volume/Balance Control can operate in one of two different modes:

- In **Differential mode** (default value), the volume control is a common volume value for both the Left and Right Loudspeaker and Headphone channels.
- In **Independent mode**, the volume for the Left and Right channels for Loudspeakers or Headphone is controlled independently.

As the Loudspeaker bass frequencies are output by the Subwoofer, its reference volume is controlled by default with the value of the [LS_CVOL](#) common volume register. The [SW_GAIN](#) register value is used to adjust the level of the Subwoofer output in regards to this reference. In Independent mode, the [SW_GAIN](#) register is used as a separated volume control and does not take into account the Loudspeaker audio level.

3.6.1 Differential Mode

The common value for the Right/Left volume controls for the Loudspeaker, Subwoofer and Headphone outputs are programmed in registers [LS_CVOL](#), [SW_GAIN](#) and [HP_CVOL](#), respectively. A differential balance can be applied using registers [LS_BAL](#) and [HP_BAL](#) to adjust the Left/Right level ratio as shown in [Figure 12](#).

Figure 12: Differential Balance

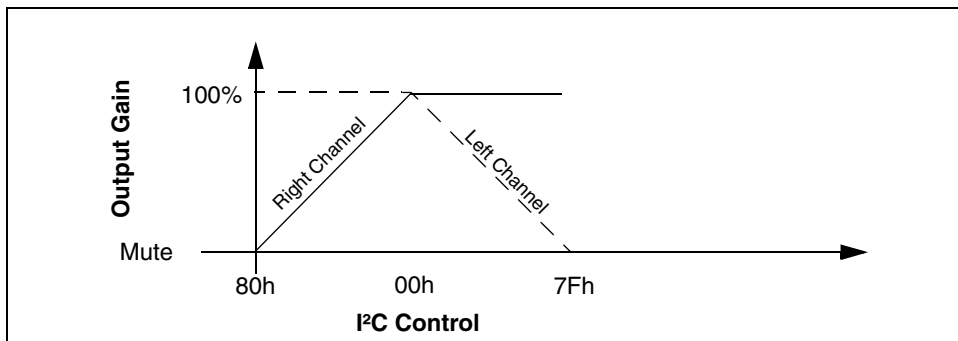

3.6.2 Independent Mode

This is enabled by setting the BAL_MODE bits in both the [LS_VOL_CTRL](#) and [HP_VOL_CTRL](#) registers to Independent mode. In this case, the register values are used to control the volume/balance functions as described in [Table 6](#).

Table 6: Volume/Balance Control Registers

Mode	LS_CVOL/LS_VOL_L HP_CVOL/HP_VOL_L Register 68h/76h	LS_BAL/LS_VOL_R HP_BAL/HP_VOL_R Register 69h/77h
LS_VOL_CTRL (Loudspeaker Volume Control)		
BAL_MODE = 0 (Independent Mode)	LS_VOL_L Left Volume value	LS_VOL_R Right Volume value
BAL_MODE = 1 (Differential Mode)	LS_CVOL Common Right/Left Volume value	LS_BAL Differential Balance value
HP_VOL_CTRL (Headphone Volume Control)		
BAL_MODE = 0 (Independent Mode)	HP_VOL_L Left Volume value	HP_VOL_R Right Volume value
BAL_MODE = 1 (Differential Mode)	HP_CVOL Common Right/Left Volume value	HP_BAL Differential Balance value

3.6.3 Mute Control

An Independent Mute Control can be used to smooth audio envelope variations in order to prevent any audible pops can be applied to all audio outputs. This feature is controlled by register [ANA_LS_HP](#).

A Headphone Detection Mode that will automatically mute the Loudspeaker and Subwoofer outputs when a headphone is detected can be enabled by the HDP_ON bit in the [ANA_LS_HP](#) register. In this case, only the Headphone output will remain active. See also [Section 3.8: Subwoofer Control](#) and [Section 5.4: Headphone Detection](#).

When a demodulated source is selected on the audio output, the mute is also controlled by Automatic Standard Recognition system (AUTOSTD). In case of no mono detected or bad detection of language without backup, the corresponding audio output is automatically muted. In case of multi-language, the output will be de-muted by selecting an other language with backup.

Table 7: Headphone/Mute Register Configuration

ANA_LS_HP Register						Output Status	
HPD_IN	HPD_ON	SW_ON	MUTE_LS	MUTE_SW	MUTE_HP	Muted	Active
X	0	0	0	X	0	SW	LS, HP Stereo
X	X	1	0	0	1	HP	LS & SW
X	X	X	1	1	1	LS, SW & HP (Channel Change: Mute All)	
X	0	1	0	0	0		LS, SW & HP Mono
0	1	0	0	0	0	SW & HP	LS (Default)
1	1	0	0	0	0	SW & LS	HP Stereo

3.7 Automatic Loudness Control

As the human ear does not hear the audio frequency range the same way depending on the power of the audio source, the Loudness Control corrects this effect by sensing the volume level and then boosting bass and treble frequencies proportionally to middle frequencies at lower volume.

While maintaining the amplitude of the 1 kHz components at an approximately constant value, the gain values of lower and higher frequencies are automatically progressively amplified up to +18 dB when the audio volume level decreases. The maximum treble amplification can be adjusted from 0 dB (first order loudness) to +18 dB (second order loudness). As the volume is proportional to the external audio amplification power, the loudness amplification threshold is programmable in order to tune the absolute level. The Loudspeaker Loudness function is enabled by setting the LOUD_ON bit in register [LS_LOUD](#). The Loudness Threshold and Maximum Treble Gain values are also programmed in this register.

Two bass cut-off frequencies are available:

- 40 Hz for Normal mode
- 120 Hz for Bass Amplified mode

The mode is selected by the LOUD_FREQ bit in register [LS_LOUD](#) (66h).

3.8 Subwoofer Control

The subwoofer signal is created by adding the bass frequency of the Left/Right Loudspeaker channels. The Subwoofer output is enabled by setting the SW_ON bit in register [ANA_LS_HP](#). This will also force the Headphone output into Mono mode.

The Subwoofer Gain and Frequency Bandwidth values are programmed in registers [SW_GAIN](#) and [SW_BAND](#), respectively. The cut-off frequency can be adjusted from between 50 and 400 Hz in steps of 50 Hz.

3.9 Beeper

The beeper is used to replace the audio signal with a tone on the Loudspeaker or Headphone outputs. It can be used for various applications such as beep sounds for remote control, alarm clock or other features.

The Beeper operates in one of two modes:

- **Pulse mode** (beep applications) A tone with a programmable short duration (between 128 ms and 1 s) is generated. Afterwards, the beeper is automatically disabled and the output is switched back to the audio signal.
- **Continuous mode** (alarm application) A tone with a programmable long duration is generated. Its start and stop controls must be programmed by I²C.

In both modes, it is recommended to use the mute function to smooth the audio-to-beeper and beeper-to-audio (Continuous mode only) transitions. The second transition is automatically muted in Pulse mode. Beeper parameters are controlled in register [BEEPER_CTRL](#).

The beeper tone level and frequency are programmed in register [BEEPER_TONE](#). The level (or volume) ranges between 0 dB and -93 dB in steps of 3 dB and the tone frequency ranges between 62.2 Hz and 8 kHz in steps of 1 octave.

A beep generator is shared only by the Loudspeaker or Headphone outputs. Therefore, in the event of simultaneous beeps when in Pulse mode, only the first beep will define the effective duration that will be the same for both outputs.

Note: The audio output is not affected by the Automatic Mute Control of Automatic Standard Recognition function when the beeper is activated.

Figure 13: Pulse Mode

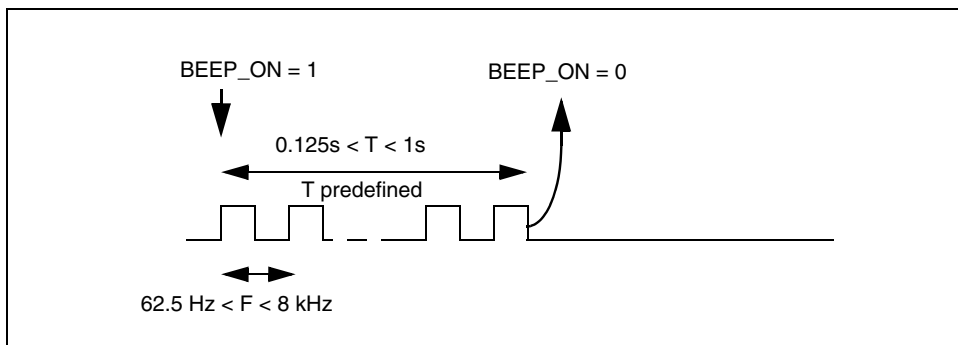
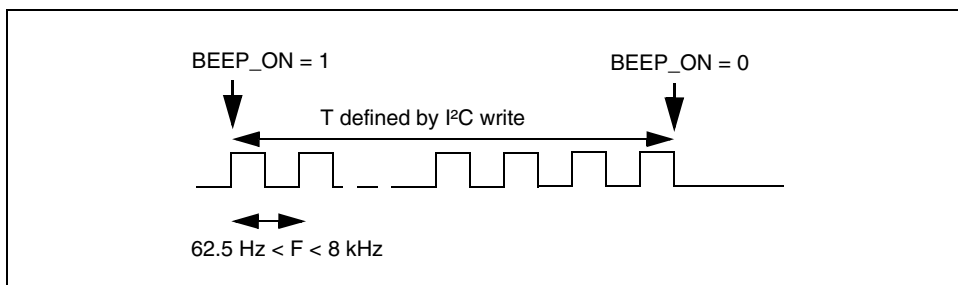

Figure 14: Continuous Mode



3.10 SRS™ 3D Surround (STV8226/36 only)

In addition to ST WideSurround, the STV8226/36 provides SRS™ 3D Stereo and Mono outputs which are spatial effects patented by SRS Labs. The SRS™ system is available on the IC when the SRS_ON bit of register [CUT_ID](#) is set (STV8226/36 identification). ST and SRS™ Surround systems cannot be used simultaneously. These signals are output only on the Loudspeaker path.

SRS™ creates a fully immersed three-dimensional soundfield through the use of a standard 2-speaker stereo configuration. For monaural audio, the source is first converted into a synthetic stereo signal before creating the 3D effect. The virtual gain for the Surround and Center components can be adjusted by registers [LS_SRS_SPACE](#) and [LS_SRS_CENTER](#) (respectively) in Stereo mode only. These values are used to adapt spatial effects to the source.

For ST WideSurround Sound, Stereo or Mono output mode is automatically selected by the Automatic Standard Recognition System (AUTOSTD) according to the detected audio source. By default, ST WideSurround Sound is selected. SRS™ Surround is selected in register [LS_SRD_CTRL](#).

4 Audio Matrices

In addition to the sound carrier source (SIF), the STV82x6 accepts up to three analog stereo audio inputs (2 V_{RMS} SCART compatible) and one analog mono audio input (0.5 V_{RMS}). These different sources can go back out through four analog stereo audio outputs which are Loudspeaker + Subwoofer and Headphone (1 V_{RMS}) and two compatible SCART audio outputs (2 V_{RMS}). An extra digital stereo output (I²S compatible) is available for interfacing with a Dolby Pro Logic Decoder or an external Digital-to-Analog Converter (DAC).

Figure 15: Audio Matrix Block Diagram

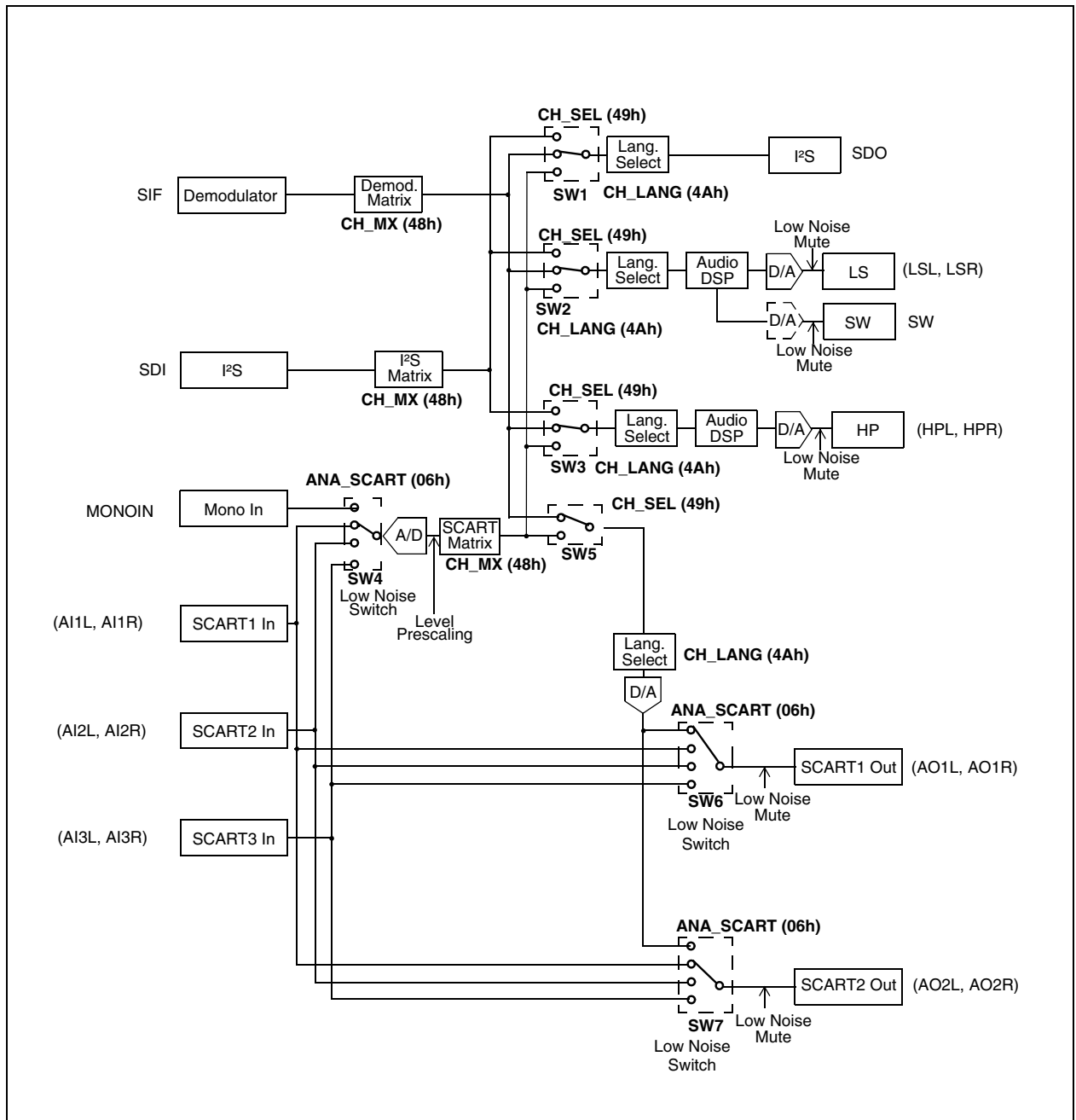

4.1 Input Audio Matrix

The mono input (MONOIN) and three stereo SCART inputs (AI1L, AIR1), (AI2L, AI2R) and (AI3L, AI3R) can be switched to any audio output and the same source can be connected to different outputs. The inputs can totally bypass the STV82x6 functions (Thru mode) via the full analog SCART path or use the audio processing corresponding to the different audio outputs. The input matrix is programmed in bits DSP_ISCART_SEL[1:0] of register [ANA_SCART](#).

In Thru mode, the STV82x6 is switched into Low Power mode (Standby) and the audio matrix configuration (ANA_SCART register) is memorized and is not reset when switched back to Full Power mode. See [Section 7.2: Standby Mode](#).

Before processing the audio signal, the selected analog input is converted into a digital 16-bit signal and pre-processed. Its sound level can be prescaled within a range between -6 dB and +6 dB in steps of 1 dB (register [PRE_AUX](#)) and for Left/Right channels (register [CH_MX](#)). The internal level can be measured with the Peak Level Detector.

4.2 Output Audio Matrix

The Loudspeaker+Subwoofer (LSL, LSR, SW), Headphone (HPL, HPR) and I²S (SDO) outputs can directly select two possible sources which are either the demodulated signal or the converted audio input (from the SCART or mono input) in register [CH_SEL](#). In the event of a dual mono source, the language is selected in register [CH_LANG](#).

The two analog SCART outputs (AO1L, AO1R) and (AO2L, AO2R) can be used to bypass the STV82x6 functions by directly selecting the analog input SCARTs or the output digital source from the demodulator or the converted audio input (with prescaling and Left/Right re-matrixing). The SCART output is selected in register [ANA_SCART](#) and the digital source in register [CH_SEL](#). In the event of a dual mono source, the language is selected in register [CH_LANG](#) as other audio outputs.

In the event of a demodulator source selection, the mute is automatically controlled for all audio outputs.

5 Additional Controls and Flags

5.1 Interrupt Request

The identified TV sound standard is displayed in register [AUTO_STAT](#). Each change in the detected standard is flagged to the host system via hardware pin IRQ. The flag must be reset by re-programming the IRQ bit in register [AUTO_CTRL](#) and then checking the detected standard status by reading registers [AUTO_STAT](#), [NICAM_STAT](#), [ZWT_STAT](#) and [CH_MX](#).

5.2 I²C Bus Expander

Pins BUS0 and BUS1 can be used to control external switchable IF SAW filters or audio switches. These pins can be directly programmed by register [CTRL](#).

5.3 Stereo Flag

For Loudspeakers only, a Stereo Mode Detection flag (the ST_ID bit in register [AUTO_STAT](#)) is set when a demodulated source is selected and a stereo standard is detected. The stereo flag is also output on pin ST in order to control an external indicator (e.g. LED). The stereo mode is also displayed by status register [AUTO_STAT](#).

CAUTION: When the I²S input is selected, the stereo flag is no longer available on pin ST.

5.4 Headphone Detection

For the headphone, the $\overline{\text{HPD}}$ input can be used to automatically mute the Loudspeaker and Subwoofer outputs when the HPD_ON bit is set in register [ANA_LS_HP](#) (active low). The $\overline{\text{HPD}}$ pin must be set for the mute function to be active.

Figure 16: Headphone Detection

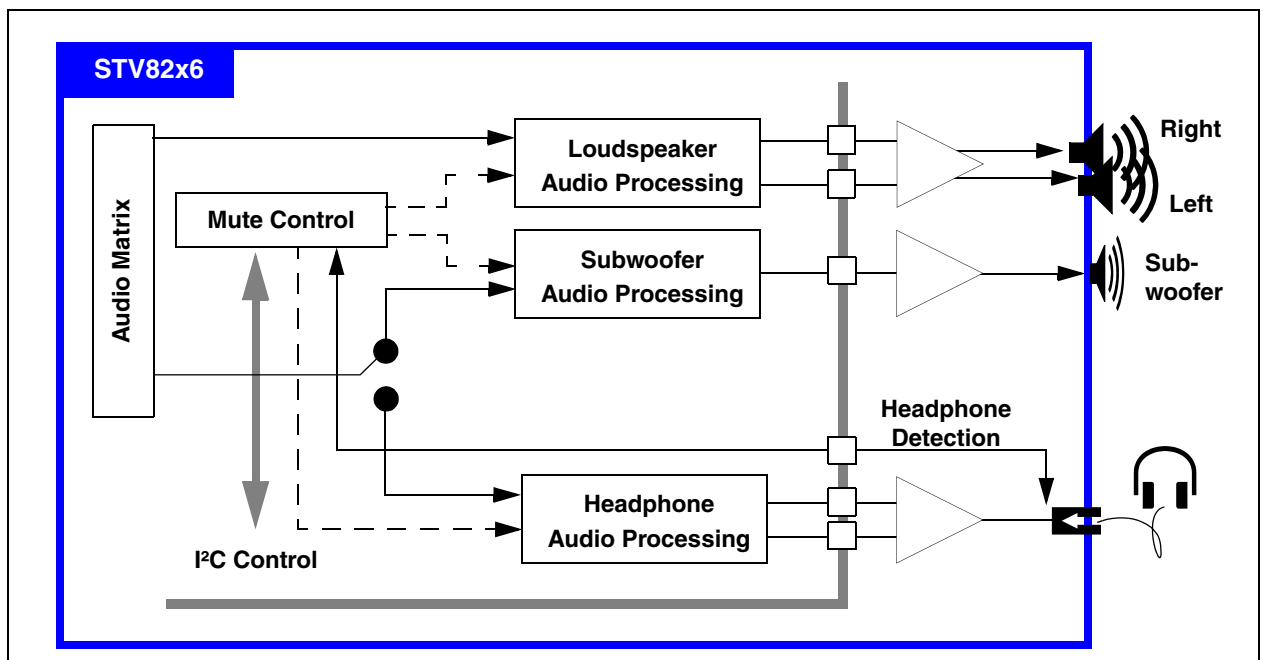

6 I²S Interface

A digital stereo input is available for a virtual Dolby source from an external decoder.

A digital stereo output (I²S compatible) is available for routing the demodulated signal or a converted input audio signal into a Dolby Pro Logic Decoder or an external DAC. The STV82x6 I²S interface drives the serial bus (SCK, WS, SDO) in Master mode in format 32.fs with a sampling frequency (f_S) of 32 kHz. An additional master clock (MCK) in format 256.fs ($f_S = 8.192$ MHz) is provided if required for the slave interface.

Both Philips and Sony modes are supported with programmable Word Selection (WS) polarity (register [I2S](#)). By default, all I²S digital outputs are set in high impedance and must be switched to low impedance via register [CTRL](#) before use.

A clock system output (SYSCK) is also available for clock peripherals using the same quartz frequency as the STV82x6. By default, this clock output (identical to the crystal oscillator) is set to high impedance and must be switched to low impedance via register [CTRL](#) before use.

7 Power Supplies

7.1 Supply Voltages

The STV82x6 supports different power configurations due to its integrated voltage regulators. Typically, two power supplies, which are grouped into two sets of IC pins, are required.

1. **Digital Power Supply (DPS)** This supply may be either 3.3 V or 5 V if an external power transistor is used. The DPS supplies pins VDD1, VDD2 and VDDP.
 - In **3.3 V mode**, the power is directly supplied to the digital power pins. In this case, the REG pin is not used and must be connected to the ground.
 - **5 V mode** requires the use of an external transistor coupled to the integrated voltage regulator via the REG pin in order to generate a stable 3.3 V supply to the digital power pins.
2. **Analog Power Supply (APS)** This supply may be either 8 V or 5 V. In both cases, external resistors are required, except for pin VDDH. The APS supplies pins VDDIF, VDDC, VDDA and VDDH.
 - The **8 V power supply** is directly connected to pin VDDH and offers a 2 V_{RMS} dynamic voltage on SCART outputs. The other analog power pins can be supplied with an 8 V or 5 V supply through external resistors.
 - If only a **5 V power supply** is available for pin VDDH, the SCART outputs will be reduced to 1 V_{RMS}. In this case, the SEL5V bit must be set in register [ANA_CTRL](#).

Figure 17: 3.3 V / 8 V or 3.3 V / 5 V Application

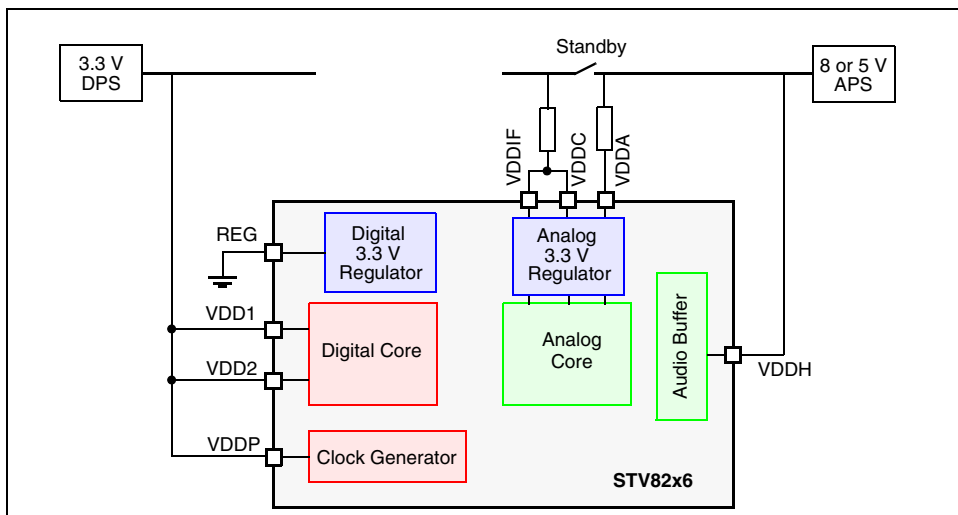
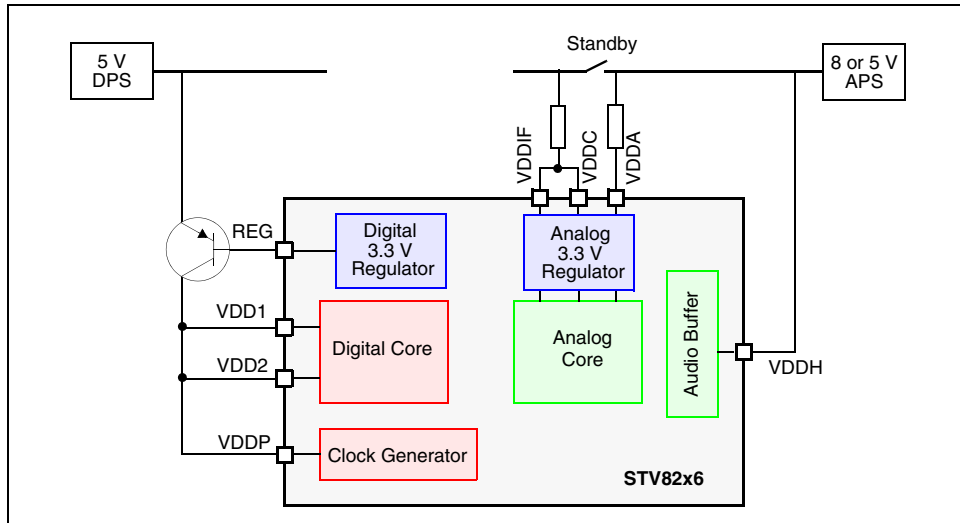

Figure 18: 5 V / 8 V or 5 V / 5 V Application



7.2 Standby Mode

The STV82x6 provides a Thru mode configuration that bypasses IC functions via a SCART I/O pin (Full Analog Path only). In this case, only minimum power is required (Standby mode).

In Standby mode, the digital and analog power supplies are switched off, except for pins VDDA and VDDH which are used to maintain the SCART path, the last configuration programmed for analog matrixing (register [ANA_SCART](#)) and the power configuration (register [ANA_CTRL](#)). When switching back to normal Full Power mode, all I²C registers are reset except for those used in Standby mode to maintain the original configuration.

In Standby mode, the I²C bus does not operate. However, the bus can still be used by other ICs since the I²C I/O pins (SDA and SCL) of the STV82x6 are forced into a high-impedance configuration.

8 I²C Bus

8.1 I²C Address and Protocol

The STV82x6 I²C interface works in Slave mode and is fully compliant with I²C standards in Fast mode (maximum frequency of 400 kHz). Two pairs of I²C chip addresses are used to connect two STV82x6 chips to the same I²C serial bus. The device address pairs are defined by the polarity of the ADR pin and are listed in the following table:

Table 8: I²C Read/Write Addresses

ADR	Write address (hex) (W)	Read address (hex) (R)
LOW (connected to GND1)	80h	81h
HIGH (connected to VDD1)	A0h	A1h

Protocol Description

- Write Protocol



- Read Protocol

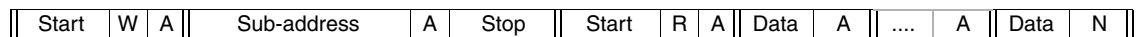

- W = Write address,
- R = Read address,
- A = Acknowledge,
- N = No acknowledge.
- Sub-address is the register address pointer; this value auto-increments for both write and read.

The STV82x6 cannot immediately reply to an I²C read request when addressing DSP registers (addresses 40h and greater). The I²C interface holds the I²C Serial Clock (SCL) line low before each data byte is read to compensate for the latency of the DSP response (64 μ s in worst case). The implemented I²C Pulling Down mode is compatible with a Continuous or Stopped SCL when held low (restart at high level, if stopped) and operates between 24 kHz and 400 kHz. If SCL Pulling Down mode is not supported by the Master I²C interface, the Pulling Down system can be deactivated by setting the SCLPD_OFF bit in register [RESET](#). In this case, two successive reads of the same DSP register are required and only the second one is valid (first read is 'don't care'). This special protocol is no longer compatible with the I²C sub-address auto-incrementation function in Read mode.

8.2 STV82x6 Reset

All STV82x6 features are controlled via the I²C bus. However, the device is designed to power up into a fully working default mode without having to be sent I²C bus data to set it up.

The STV82x6 can be "reset" in 2 ways:

1. By Software via the I²C bus: This clears all synchronous logic, except for the I²C bus registers.
2. By Hardware via the RESET pin: In addition to clearing all synchronous logic, the RESET input (active low) resets all the I²C bus registers to the *default values* listed below.

Table 9: RESET Default Values

Function	Default mode
Demodulation	
Auto-standard	ON
Scanned Standards	M/N, B/G, I, L/L'
FM Deviation	± 125 kHz (Max.)
Audio Outputs	
Automatic Mute Mode	ON
Loudspeaker Source	Demodulated Sound
Loudspeaker Volume	-48 dB / muted
Loudspeaker L/R Balance	L/R = 100%
Subwoofer	-48 dB / OFF
Headphone Source	Demodulated Sound
Headphone Automatic Detection	ON
Headphone Volume	-48 dB / Muted
Headphone L/R Balance	L/R = 100%
SCART-1 out	Demodulated Sound
SCART-2 out	SCART1 Source
I ² S out	OFF
Audio Processing	
Loudspeaker/Headphone SVC	OFF, 0 dB Reference Value
Loudspeaker Surround	OFF
Loudspeaker 5-Band Equalizer	OFF, 0 dB (Flat Band)
Loudspeaker Loudness	OFF
Headphone Bass/Treble	OFF, 0 dB (Flat Band)
Loudspeaker/Headphone Beeper	-48 dB / OFF

9 Register List

Note: The unused bits (defined as reserved) in I²C registers must be kept to zero.

The system clock registers (from address 08h to 0Bh) do not need to be modified if a standard 27 MHz quartz crystal is used

The demodulator registers (from address 0Ch to 54h) default values are optimum and any change is not recommended, except for:

- AGCS (0Fh) to adjust AGC gain for AM carrier in L/L' standard (AGC used in open loop)
- CAROFFSET1(22h) and CAROFFSET2(3Ah) to compensate IF carrier frequency with an out-of-standard offset
- Soundlevel Prescaling PRE_FM(44h), PRE_NICAM(45h) and PRE_AUX(46h) to equalize demodulated or external audio signal before audio processing. Peak detector registers PEAK_DET_CTRL(4Bh) and PEAK_DET_STAT(4Ch) can be used to measure internal sound level.
- Sound source selection for each audio output channel Loudspeaker+Subwoofer, Headphone, SCART and I²S to be done using CH_SEL(49h)
- In Multi-lingual mode, CH_LANG(4Ah) selects separately the language for each audio output channel.
- AUTO_CTRL(50h) to select between L/L' or D/K/K1/K2/K3 standard which can be discriminated automatically. To be used also to change maximum FM deviation (125 kHz, by default) in case of wide overmodulation.
- AUTO_SCKM(51h) and AUTO_SCKST(52h) to define the list of mono and stereo standards to be recognized automatically.

Note: () used in reset value column means that the bit or the byte is read-only.

(S) symbol indicates that the field value is represented in signed binary format.

(*) The field **AGC_ERR[4:0]** (AGCS) can be written by user if the bit **AGC_CMD** (AGCC) is set to one (by default controlled by AUTOSTD). To be used to adjust manually the input gain of analog AGC amplifier for AM carrier (L/L').

9.1 I²C Register Map

By default, all I²C registers controlled by Automatic Standard Recognition System (AUTOSTD) are forced to Read-only mode for the user. These registers and bits are shaded in [Table 10](#).

Table 10: List of I²C Registers (Sheet 1 of 5)

Name	Addr. (Hex)	Reset Value (Bin)	Register Function and Description							
			Bit 7	Bit 6	Bit 5	Bit 4	Bit 3	Bit 2	Bit 1	Bit 0
IC General Control										
CUT_ID	00h	(0001 0001)	SRS_ON	0	CUT_NUMBER[5:0]					
RESET	02h	0000 0000	0	SCLPD_OF F	AUTO_OFF	0	0	SOFT_LRS T1	SOFT_LRS T2	SOFT_RST
CTRL	03h	0000 0000	0	BUS_EXPAND[1:0]		I ² S_EN	SDI_EN	0	MCK_EN	SYSCK_EN
I2S	04h	0000 0000	0	0	0	0	I2S_STD	I2S_WSPO L	0	0

Table 10: List of I²C Registers (Sheet 2 of 5)

Name	Addr. (Hex)	Reset Value (Bin)	Register Function and Description							
			Bit 7	Bit 6	Bit 5	Bit 4	Bit 3	Bit 2	Bit 1	Bit 0

Audio Mute & Switch

ANA_CTRL	05h	0000 0000	SEL5V	0	0	0	0	0	0	0	0
ANA_SCART	06h	0010 1100	DSP_ISCART_SEL[1:0]		MUTE_OSC ART2	OSCART2_SEL[1:0]		MUTE_OSC ART1	OSCART1_SEL[1:0]		
ANA_LS_HP	07h	(0)100 0111	HPD_IN	HPD_ON	SW_ON	0	0	MUTE_LS	MUTE_SW	MUTE_HP	

Clocking

PLL_DIV	08h	0000 0101	0	0	SDIV[2:0]			FDIV[2:0]			
PLL_MD	09h	0001 1110	0	0	0	MD2[4:0]					
PLL_PEH	0Ah	0000 0001	0	0	0	0	PE1[11:8]				
PLL_PEL	0Bh	1110 1000	PE1[7:0]								

Demodulator

DEMOD_CTRL	0Ch	0000 0110	0	0	0	0	AM_SEL	DEMOD_MODE[2:0]			
DEMOD_STAT	0Dh	(0000 0000)	0	0	0	QPSK_LK	FM2_CAR	FM2_SQ	FM1_CAR	FM1_SQ	
AGCC	0Eh	0001 0001	AGC_CMD	0	0	AGC_REF[2:0]			AGC_CST[1:0]		
AGCS	0Fh	(0000 0000)	0	AGC_ERR[4:0] (*)					SIG_OVER	SIG_UNDE R	
DCS	10h	(0000 0000)	DC_ERR[7:0]								

Demodulator Channel 1

CARFQ1H	12h	0011 1110	CARFQ1[23:16]								
CARFQ1M	13h	1000 0000	CARFQ1[15:8]								
CARFQ1L	14h	0000 0000	CARFQ1[7:0]								
FIR1C0	15h	0000 0000	FIR1C0[7:0] (S)								
FIR1C1	16h	1111 1110	FIR1C1[7:0] (S)								
FIR1C2	17h	1111 1100	FIR1C2[7:0] (S)								
FIR1C3	18h	1111 1101	FIR1C3[7:0] (S)								
FIR1C4	19h	0000 0010	FIR1C4[7:0] (S)								
FIR1C5	1Ah	0000 1101	FIR1C5[7:0] (S)								
FIR1C6	1Bh	0001 1000	FIR1C6[7:0]6 (S)								
FIR1C7	1Ch	0001 1111	FIR1C7[7:0] (S)								
ACOEFF1	1Dh	0010 0011	ACOEFF1[7:0]								
BCOEFF1	1Eh	0001 0010	BCOEFF1[7:0]								
CRF1	1Fh	(0000 0000)	CRF[7:0] (S)								
CETH1	20h	0010 0000	CETH1[7:0]								
SQTH1	21h	0011 1100	SQTH1[7:0]								
CAROFFSET1	22h	0000 0000	CAROFFSET1[7:0] (S)								

Demodulator Channel 2

IAGCR	25h	1000 1000	IAGC_REF[7:0]								
IAGCC	26h	0000 0011	IAGC_OFF	0	0	0	0	IAGC_CST[2:0]			

Table 10: List of I²C Registers (Sheet 3 of 5)

Name	Addr. (Hex)	Reset Value (Bin)	Register Function and Description							
			Bit 7	Bit 6	Bit 5	Bit 4	Bit 3	Bit 2	Bit 1	Bit 0
IAGCS	27h	(0000 0000)	IAGC_CTRL[7:0]							
CARFQ2H	28h	0100 0100	CARFQ2[23:16]							
CARFQ2M	29h	0100 0000	CARFQ2[15:8]							
CARFQ2L	2Ah	0000 0000	CARFQ2[7:0]							
FIR2C0	2Bh	0000 0000	FIR2C0[7:0] (S)							
FIR2C1	2Ch	0000 0000	FIR2C1[7:0] (S)							
FIR2C2	2Dh	0000 0000	FIR2C2[7:0] (S)							
FIR2C3	2Eh	0000 0000	FIR2C3[7:0] (S)							
FIR2C4	2Fh	1111 1111	FIR2C4[7:0] (S)							
FIR2C5	30h	0000 0100	FIR2C5[7:0] (S)							
FIR2C6	31h	0001 0100	FIR2C6[7:0] (S)							
FIR2C7	32h	0010 0101	FIR2C7[7:0] (S)							
ACOEFF2	33h	1001 0000	ACOEFF2[7:0]							
BCOEFF2	34h	1010 1100	BCOEFF2[7:0]							
SCOEFF	35h	0001 1100	SCOEFF[7:0]							
SRF	36h	(0000 0000)	SRF[7:0] (S)							
CRF2	37h	(0000 0000)	CRF2[7:0] (S)							
CETH2	38h	0010 0000	CETH2[7:0]							
SQTH2	39h	0011 1100	SQTH2[7:0]							
CAROFFSET2	3Ah	0000 0000	CAROFFSET2[7:0] (S)							

NICAM

NICAM_CTRL	3Dh	0000 0000	0	0	0	0	0	DIF_POL	ECT	MAE
NICAM_BER	3Eh	(0000 0000)	ERROR[7:0]							
NICAM_STAT	3Fh	(0000 0000)	NIC_DET	F_MUTE	LOA	CBI[4:1]			NIC_MUTE	

Stereo FM

ZWT_CTRL	40h	0011 0001	0	STD_MODE	THRESH[3:0]			TSCTRL[1:0]		
ZWT_STAT	41h	(0000 0000)	0	0	0	0	0	ZW_DET	ZW_ST	ZW_DM

Sound Preprocessing & Selection

FM_DCL	42h	(0000 0000)	FM_DCL[7:0] (S)							
FM_DCR	43h	(0000 0000)	FM_DCR[7:0] (S)							
PRE_FM	44h	0000 0110	0	0	FM_PRESCALE[5:0] (S)					
PRE_NICAM	45h	0000 1101	0	0	NICAM_PRESCALE[5:0] (S)					
PRE_AUX	46h	0000 0000	I2S_PRESCALE[3:0] (S)				SCART_PRESCALE[3:0] (S)			
CH_CTRL	47h	0000 0000	MUTE_D01 2	MUTE_D12	NIC_DMx	NICDPH_O FF	FM_DMx[1:0]		FMDPH_OF F	FMDPH_S W
CH_MX	48h	0000 0000	I2S_MX[1:0]		SC_MX[1:0]		DEMOM_MX[3:0]			
CH_SEL	49h	0000 0000	I2S_SEL[1:0]		SC_SEL[1:0]		HP_SEL[1:0]		LS_SEL[1:0]	
CH_LANG	4Ah	0000 0000	I2S_LANG[1:0]		SC_LANG[1:0]		HP_LANG[1:0]		LS_LANG[1:0]	

Table 10: List of I²C Registers (Sheet 4 of 5)

Name	Addr. (Hex)	Reset Value (Bin)	Register Function and Description							
			Bit 7	Bit 6	Bit 5	Bit 4	Bit 3	Bit 2	Bit 1	Bit 0
PEAK_DET_CTRL	4Bh	0000 0000	0	0	0	0	0	0	0	PD_SEL[1:0]
PEAK_DET_STATL	4Ch	(0000 0000)	PEAK_LEVEL_LEFT[7:0]							
PEAK_DET_STATR	4Dh	(0000 0000)	PEAK_LEVEL_RIGHT[7:0]							

Automatic Standard Recognition System

AUTO_CTRL	50h	0000 0001	0	0	0	IRQ	SINGLE_SHOT	DK_DEV[1:0]		LDK_SW
AUTO_SCKM	51h	0000 1111	0	0	0	0	LDK_SCK	I_SCK	BG_SCK	MN_SCK
AUTO_SCKST	52h	0001 1111	LDK_ZWT3	LDK_ZWT2	LDK_SWT1	LDK_NIC	I_NIC	BG_ZWT	BG_NIC	MN_ZWT
AUTO_TIMER	53h	1010 0100	FM_TIME[1:0]		NICAM_TIME[2:0]			ZWEITON_TIME[2:0]		
AUTO_STAT	54h	0(000 0000)	ST_ID	STEREO_STATE	MONO_STATE	AUTO_ON	STEREO_SID[1:0]		MONO_SID[1:0]	

Audio Processing

SVC_SEL	59h	0000 0000	0	0	0	0	0	0	0	SVC_SW
SVC_CTRL	5Ah	0000 0000	SVC_ON	SVC_TIME[1:0]		SVC_REF[4:0] (S)				
LS_SRD_CTRL	5Bh	0000 0000	SRD_ON	0	0	0	0	SRD_SEL	SRD_STEREO	STS_MODE
LS_STS_GAIN	5Ch	1000 0000	ST_GAIN[7:0]							
LS_STS_FREQ	5Dh	00010101	0	0	BASS_FREQ[1:0]		MEDIUM_FREQ[1:0]		TREBLE_FREQ[1:0]	
LS_SRS_SPACE	5Eh	1000 0000	SRS_SPACE[7:0] (for Stereo mode only)							
LS_SRS_CENTER	5Fh	1000 0000	SRS_CENTER[7:0] (for Stereo mode only)							
LS_EQ_CTRL	60h	0000 0000	EQ_ON	0	0	0	0	0	0	R
LS_EQ_BAND1	61h	0000 0000	0	0	0	EQ_BAND1_GAIN[4:0] (S)				
LS_EQ_BAND2	62h	0000 0000	0	0	0	EQ_BAND2_GAIN[4:0] (S)				
LS_EQ_BAND3	63h	0000 0000	0	0	0	EQ_BAND3_GAIN[4:0] (S)				
LS_EQ_BAND4	64h	0000 0000	0	0	0	EQ_BAND4_GAIN[4:0] (S)				
LS_EQ_BAND5	65h	0000 0000	0	0	0	EQ_BAND5_GAIN[4:0] (S)				
LS_LOUD	66h	0000 0010	LOUD_TH_ON	LOUD_TH[2:0]			LOUD_FREQ	LOUD_TH_GHR[2:0]		
LS_VOL_CTRL	67h	0000 0001	0	0	0	0	0	0	0	BAL_MODE
LS_CVOL/ LS_VOL_L	68h	1000 0000	CVOL[7:0]							
LS_BAL/ LS_VOL_R	69h	0000 0000	BAL[7:0] (S)							
SW_GAIN	6Ah	1000 0000	SW_GAIN[5:0]							
SW_BAND	6Bh	0000 0011	0	0	0	0	0	SW_FREQ[2:0]		

Headphone Channel

HP_BT_CTRL	71h	0000 0000	BT_ON	0	0	0	0	0	0	0
HP_BASS_GAIN	72h	0000 0000	0	0	0	BASS_GAIN[4:0] (S)				
HP_TREBLE_GAIN	73h	0000 0000	0	0	0	TREBLE_GAIN[4:0] (S)				
HP_VOL_CTRL	75h	0000 0001								BAL_MODE

Table 10: List of I²C Registers (Sheet 5 of 5)

Name	Addr. (Hex)	Reset Value (Bin)	Register Function and Description							
			Bit 7	Bit 6	Bit 5	Bit 4	Bit 3	Bit 2	Bit 1	Bit 0
HP_CVOL/ HP_VOL_L	76h	1000 0000	CVOL[7:0]							
HP_BAL/ HP_VOL_R	77h	0000 0000	BAL[7:0] (S)							
Beeper										
BEEPER_CTRL	79h	0000 0000	LS_BEEP_ON	HP_BEEP_ON	BEEP_MODE	0	0	0	BEEP_DURATION[1:0]	
BEEPER_TONE	7Ah	0111 0000	BEEP_FREQ[2:0]			BEEP_VOL[4:0]				

9.2 STV82x6 General Control Registers

CUT_ID

Version Identification

Address (hex): 00h

Type: R

Bit 7	Bit 6	Bit 5	Bit 4	Bit 3	Bit 2	Bit 1	Bit 0
SRS_ON	0	CUT_NUMBER[5:0]					

Bit Name	Reset	Function
SRS_ON	0	Identifies the STV82x6 version 0: version without SRS™ (STV82x6) - Only ST WideSurround can be used 1: version with SRS™ (STV8226/36) - Both SRS™ and ST WideSurround are available
Bit 6	0	Reserved.
CUT_NUMBER[5:0]	010001	Dice Version Identification

RESET

Software Reset Register

Address (hex): 02h

Type: R/W

Bit 7	Bit 6	Bit 5	Bit 4	Bit 3	Bit 2	Bit 1	Bit 0
0	SCLPD_OFF	AUTO_OFF	0	0	SOFT_LRST1	SOFT_LRST2	SOFT_RST

Description

The built-in Automatic Standard Recognition System (AUTOSTD) can be disabled by bit AUTO_OFF (when high). In this case, the Software Reset function (bits SOFT_LRESTART1 and SOFT_LRESTART2) can be used to implement the Automatic Standard Recognition by I²C Software. This is not required if the built-in Automatic Standard Recognition System function is used (default).

Bit Name	Reset	Function
Bit7	0	Reserved.
SCLPD_OFF		SCL Pulling-down System Disable 0: System is enabled 1: System is disabled
AUTO_OFF	0	Automatic Standard Recognition System Disable 0: System is enabled 1: System is disabled
Bits[4:3]	00	Reserved.
SOFT_LRESTART1	0	Softreset (active high) of Channel 1 detectors only.
SOFT_LRESTART2	0	Softreset (active high) of Channel 2 detectors only.
SOFTTRST	0	General softreset (active high) to reset all hardware registers except for I ² C data.

CTRL**Hardware Interface Control Register**

Address (hex): 03h

Type: R/W

Bit 7	Bit 6	Bit 5	Bit 4	Bit 3	Bit 2	Bit 1	Bit 0
0	BUS_EXPAND[1:0]	I2S_EN	SDI_EN	0	MCK_EN	SYSCK_EN	

Description

Provides all hardware controls to drive external components (SAW Filter, Audio Switches) and additional Audio Decoder (Dolby Pro Logic) via register [I2S](#) including the Master and Quartz Clocks.

Bit Name	Reset	Function
Bit 7	0	Reserved.
BUS_EXPAND[1:0]	00	Static control by I ² C of hardware pins BUS1 and BUS0.
I2S_EN	0	When 1, the I ² S hardware pin is enabled (SCK, WS, SDO)
SDI_EN	0	When 1, the SDI input pin is enabled (switch with ST output). Must be used when I ² S mode is selected.
Bit 2	0	Reserved.
MCK_EN	0	Master Clock Enable Enables the master clock output (256.fs) to interface by I ² S with the Dolby Pro Logic Decoder. 0: Disabled. 1: Enabled
SYSCK-EN	0	System Clock Enable Enables the system clock output to provide the quartz clock required to interface with the Dolby Pro Logic Decoder. 0: Disabled. 1: Enabled

I2S**I²S Interface Control Register**

Address (hex): 04h

Type: R/W

Bit 7	Bit 6	Bit 5	Bit 4	Bit 3	Bit 2	Bit 1	Bit 0
0	0	0	0	I2S_STD	I2S_WSPOL	0	0

Description

Proposes most used I²S standard (Philips and Sony) with Word Select (WS) polarity programming. Only Master mode is supported. All interfaced chip must be set in slave mode.

Bit Name	Reset	Function
Bits[7:4]	0000	Reserved.
I2S_STD	0	I²S Standard Select 0: Philips Standard (Default) 1: Sony Standard
I2S_WSPOL	0	I²S Word Select Polarity Select 0: No WS inversion (Default) 1: WS with polarity inversion
Bits[1:0]	00	Reserved.

9.3 Analog Block**ANA_CTRL****Power Supply Configuration Control Register**

Address (hex): 05h

Type: R/W

Bit 7	Bit 6	Bit 5	Bit 4	Bit 3	Bit 2	Bit 1	Bit 0
SEL5V	0	0	0	0	0	0	0

Bit Name	Reset	Function
SEL5V	0	5 V Analog Power Supply Select The audio power amplifiers should be muted before changing this bit. 0: 8 V Analog Power Supply (Default). 1: 5 V Analog Power Supply
Bit[6:0]	0000000	Reserved

ANA_SCART**SCART Control Register**

Address (hex): 06h

Type: R/W

Bit 7	Bit 6	Bit 5	Bit 4	Bit 3	Bit 2	Bit 1	Bit 0
DSP_ISCART_SEL[1:0]	MUTE_OSCA RT2	OSCART2_SEL[1:0]	MUTE_OSCA RT1	OSCART1_SEL[1:0]			

Bit Name	Reset	Function
DSP_ISCART_SEL[1:0]	00	Analog Audio Matrixing for Mono and SCART Inputs (with Low Noise Audio Switching) 00: ISCART1 (Default) 01: ISCART2 10: ISCART3 11: Mono input
MUTE_OSCART2	1	0: No Mute 1: x Output muted
OSCART2_SEL [1:0]	01	Analog Audio Matrixing for SCART outputs (with Low Noise Audio Switching) 00: DSP_OSCART 01: ISCART1 (Default) 10: ISCART2 11: ISCART3
MUTE_OSCART1	1	0: No Mute 1: x Output muted
OSCART1_SEL [1:0]	00	00: DSP_OSCART (Default) 01: ISCART1 10: ISCART2 11: ISCART3

Note: SCART I²C programming (matrixing and mute control) is maintained during Standby mode

Before switching to Standby mode, the output SCART mute is recommended if the demodulated sound source (DSP_OSCART) is selected by this output. This source might cause an audible plop during the digital power down.

ANA_LS_HP**Loudspeaker/Subwoofer/Headphone Mute Control****ANA_LS/HP**

Address (hex): 07h

Type: R/W

Bit 7	Bit 6	Bit 5	Bit 4	Bit 3	Bit 2	Bit 1	Bit 0
HPD_IN	HPD_ON	SW_ON	0	0	MUTE_LS	MUTE_SW	MUTE_HP

Bit Name	Reset	Function
HPD_IN	0	Headphone Input Pin Status Read only I ² C bit that displays the $\overline{\text{HPD}}$ pin Status 0: Headphone is detected 1: Headphone is not detected
HPD_ON	0	Headphone Detection Enable 0: Headphone Detection is disabled 1: Headphone Detection is enabled. If the HPD_IN bit is set, the Loudspeaker and Subwoofer mute is activated
SW_ON	0	Subwoofer Enable Before switching on/off the subwoofer, a mute is recommended to prevent an audible plop. 0: Subwoofer is disabled. Headphone output is selected. 1: Subwoofer is enabled. Subwoofer output is selected and Headphone output is in Mono mode
Bits[4:3]	00	Reserved.
MUTE_LS MUTE_SW MUTE_HP	000	000: LS + SW + HP mono 100: Not used. 001: LS + SW 101: Not used. 010: LS + HP stereo 110: HP stereo only. 011: LS only 111: All muted (Default)

9.4 Clocking

A low-jitter PLL Clock is integrated and can be fully reprogrammed using the registers described below. By default, the programming is defined for a 27-MHz quartz crystal frequency, which is the frequency recommended for reducing potential RF interference in the application. (See [Section 2.2: System Clock](#).) However, if necessary, the PLL Clock can be re-programmed for other quartz crystal frequencies within a range from 23 to 30 MHz. Other quartz crystal frequencies can be programmed on your demand.

Note: A Crystal Frequency change is compatible with other default I²C programming including the built-in Automatic Standard Recognition System.

PLL_DIV

PLL Frequency Divider Register

Address (hex): 08h

Type: R/W

Bit 7	Bit 6	Bit 5	Bit 4	Bit 3	Bit 2	Bit 1	Bit 0
0	0	SDIV[2:0]			FDIV[2:0]		

Bit Name	Reset	Function
Bits[7:6]	00	Reserved.
SDIV[2:0]	000	PLL Frequency S-Divider
FDIV[2:0]	101	PLL Frequency F-Divider

PLL_MD**PLL Coarse Frequency Control Register**

Address (hex): 09h

Type: R/W

Bit 7	Bit 6	Bit 5	Bit 4	Bit 3	Bit 2	Bit 1	Bit 0
0	0	0	MD2[4:0]				

Bit Name	Reset	Function
Bits[7:5]	000	Reserved.
MD2[4:0]	11110	PLL Coarse Frequency Control

PLL_PEH**PLL Fine Frequency Control Register (MSBs)**

Address (hex): 0Ah

Type: R/W

Bit 7	Bit 6	Bit 5	Bit 4	Bit 3	Bit 2	Bit 1	Bit 0
0	0	0	0	PE1[11:8]			

Bit Name	Reset	Function
Bits[7:4]	000	Reserved.
PE1[11:8]	0001	PLL Fine Frequency Control (4 MSBs)

PLL_PEL**PLL Fine Frequency Control Register (LSBs)**

Address (hex): 0Bh

Type: R/W

Bit 7	Bit 6	Bit 5	Bit 4	Bit 3	Bit 2	Bit 1	Bit 0
PE1[7:0]							

Bit Name	Reset	Function
PE1[7:0]	11101000	PLL Fine Frequency Control (8 LSBs)

9.5 Demodulator

DEMOD_CTRL

Demodulator Control Register

Address (hex): 0Ch

Type: R/W

Bit 7	Bit 6	Bit 5	Bit 4	Bit 3	Bit 2	Bit 1	Bit 0
0	0	0	0	AM_SEL	DEMOD_MODE[2:0]		

Bit Name	Reset	Function																					
Bits[7:4]	0000	Reserved.																					
AM_SEL	0	Demodulator Configuration Select 0: FM configuration of demodulator (Default) 1: AM configuration of demodulator																					
DEMOD_MODE[2:0]	110	Demodulator Mode Select <table border="0"> <thead> <tr> <th></th> <th><u>CH1 FM</u></th> <th><u>CH2 FM/QPSK</u></th> </tr> </thead> <tbody> <tr> <td>X00:</td> <td>Normal</td> <td>FM Normal</td> </tr> <tr> <td>X01:</td> <td>Wide</td> <td>FM Wide</td> </tr> <tr> <td>010:</td> <td>Normal</td> <td>QPSK System B/G/L/D/K</td> </tr> <tr> <td>011:</td> <td>Wide</td> <td>QPSK System B/G/L/D/K</td> </tr> <tr> <td>110:</td> <td>Normal</td> <td>QPSK System I</td> </tr> <tr> <td>111:</td> <td>Wide</td> <td>QPSK System I</td> </tr> </tbody> </table>		<u>CH1 FM</u>	<u>CH2 FM/QPSK</u>	X00:	Normal	FM Normal	X01:	Wide	FM Wide	010:	Normal	QPSK System B/G/L/D/K	011:	Wide	QPSK System B/G/L/D/K	110:	Normal	QPSK System I	111:	Wide	QPSK System I
	<u>CH1 FM</u>	<u>CH2 FM/QPSK</u>																					
X00:	Normal	FM Normal																					
X01:	Wide	FM Wide																					
010:	Normal	QPSK System B/G/L/D/K																					
011:	Wide	QPSK System B/G/L/D/K																					
110:	Normal	QPSK System I																					
111:	Wide	QPSK System I																					

DEMOD_STAT

Demodulator Detection Status Register

Address (hex): 0Dh

Type: R

Bit 7	Bit 6	Bit 5	Bit 4	Bit 3	Bit 2	Bit 1	Bit 0
0	0	0	QPSK_LK	FM2_CAR	FM2_SQ	FM1_CAR	FM1_SQ

Bit Name	Reset	Function
Bit [7:5]	000	Reserved.
QPSK_LK	0	QPSK Lock detection flag 0: Not detected 1: Detected
FM2_CAR	0	Channel 2 FM/AM Carrier detector flag 0: Not detected 1: Detected
FM2_SQ	0	Channel 2 FM Squelch detector flag 0: Not detected 1: Detected

Bit Name	Reset	Function
FM1_CAR	0	Channel 1 FM/AM Carrier detector flag 0: Not detected 1: Detected
FM1_SQ	0	Channel 1 FM Squelch detector flag 0: Not detected 1: Detected

Note: These registers allow direct access to the demodulator signal detectors.

AGCC**AGC Control for IF ADC**

Address (hex): 0Eh

Type: R/W

Bit 7	Bit 6	Bit 5	Bit 4	Bit 3	Bit 2	Bit 1	Bit 0
AGC_CMD	0	0	AGC_REF[2:0]			AGC_CST[1:0]	

Bit Name	Reset	Function																				
AGC_CMD	0	Automatic Gain Control Command Mode Normally set to 0 enabling automatic mode. For L/L' standards, the AGC should be switched off due to the presence of the AM sound carrier. In this case, a fixed gain value should be set using the AGCS register. 0: Automatic mode. AGC controlled by the AUTOSTD function. (Default) 1: Manual/Forced mode																				
Bits[6:5]	00	Reserved.																				
AGC_REF[2:0]	100	This bitfield is used to defines the clipping level which adjusts the allowable proportion of samples at the input of the ADC which will be clipped. The AGC tries to maximize the use of the full scale range of the ADC. The default setting gives a ratio of 1/256. <table border="0"> <thead> <tr> <th colspan="2"><u>Clipping Ratio</u></th> <th colspan="2"><u>Clipping Ratio</u></th> </tr> </thead> <tbody> <tr> <td>000:</td> <td>1/16 (Single carrier)</td> <td>100:</td> <td>1/256 (Default)</td> </tr> <tr> <td>001:</td> <td>1/32</td> <td>101:</td> <td>1/512</td> </tr> <tr> <td>010:</td> <td>1/64</td> <td>110:</td> <td>1/1024</td> </tr> <tr> <td>011:</td> <td>1/128</td> <td>111:</td> <td>1/2048 (Multiple carriers)</td> </tr> </tbody> </table>	<u>Clipping Ratio</u>		<u>Clipping Ratio</u>		000:	1/16 (Single carrier)	100:	1/256 (Default)	001:	1/32	101:	1/512	010:	1/64	110:	1/1024	011:	1/128	111:	1/2048 (Multiple carriers)
<u>Clipping Ratio</u>		<u>Clipping Ratio</u>																				
000:	1/16 (Single carrier)	100:	1/256 (Default)																			
001:	1/32	101:	1/512																			
010:	1/64	110:	1/1024																			
011:	1/128	111:	1/2048 (Multiple carriers)																			
AGC_CST[1:0]	01	AGC Time Constant This is the time constant between each step of 1.25 dB by the ADC. <table border="0"> <thead> <tr> <th colspan="2"><u>Step Duration (ms)</u></th> </tr> </thead> <tbody> <tr> <td>00</td> <td>1.33</td> </tr> <tr> <td>01</td> <td>2.66</td> </tr> <tr> <td>10</td> <td>5.33</td> </tr> <tr> <td>11</td> <td>10.66</td> </tr> </tbody> </table>	<u>Step Duration (ms)</u>		00	1.33	01	2.66	10	5.33	11	10.66										
<u>Step Duration (ms)</u>																						
00	1.33																					
01	2.66																					
10	5.33																					
11	10.66																					

AGCS**AGC Control and Status for IF ADC**

Address (hex): 0Fh

Type: R

Bit 7	Bit 6	Bit 5	Bit 4	Bit 3	Bit 2	Bit 1	Bit 0
0	AGC_ERR[4:0]					SIG_OVER	SIG_UNDER

Bit Name	Reset	Function
Bit 7	0	Reserved.
AGC_ERR[4:0]	00000	Amplifier Gain Control This is the Gain Control value of ADC. There are 31 steps of +1.25 dB (see Note below). 00000: 0 dB Gain 11110: +37.5 dB Gain
SIG_OVER	0	AGC Input Signal Upper Threshold 0: Normal signal 1: Signal too large and AGC is overloaded
SIG_UNDER	0	AGC Input Signal Lower Threshold 0: Normal signal 1: Signal too small and AGC is underloaded When the AGC is in Automatic mode (AGC_CMD = 0), bits SIG_OVER and SIG_UNDER indicate if the input signal is too small/large and the AGC is under/overloaded. This is useful when setting the STV82x6 SIF input level.

Note: When **AGC_CMD = 0**, **AGC_ERR[4:0]** can be read -- indicating the input level. It can also be written to -- presetting the AGC level which will then adjust itself to the final value.

When **AGC_CMD = 1**, the AGC is off and writing to **AGC_ERR[4:0]** directly controls the AGC amplifier gain. Reading AGC_ERR just confirms the fixed value.

DCS**DC Offset Status for IF ADC**

Address (hex): 10h

Type: R

Bit 7	Bit 6	Bit 5	Bit 4	Bit 3	Bit 2	Bit 1	Bit 0
DC_ERR[7:0]							

Bit Name	Reset	Function
DC_ERR[7:0]	00000000	DC offset error of IF ADC output

9.6 Demodulator Channel 1

CARFQ1H, CARFQ1M, CARFQ1L Channel 1 Carrier DCO Frequency

Address (hex): 13h to 15h

Type: R/W

Bit 7 Bit 6 Bit 5 Bit 4 Bit 3 Bit 2 Bit 1 Bit 0

CARFQ1[23:16], CARFQ1[15:8], CARFQ1[7:0]

Bit Name	Reset	Function
CARFQ1[13:8]	00111110	Channel 1 DCO Carrier Frequency (8 MSBs)
]CARFQ1[13:8]	10000000	Channel 1 DCO Carrier Frequency
CARFQ1[7:0]	00000000	Channel 1 DCO Carrier Frequency (8LSBs)

Table 11: Mono Carrier Frequencies by System

System	Mono Carrier Freq. (MHz)	CARFQ1[23:0] (dec)	CARFQ1[23:0] (hex)
M/N	4.5	3072000	2EE000h
B/G	5.5	3754667	394AABh
I	6.0	4096000	3E8000h
L	6.5	4453717	43F555h
D/K/K1/K2	6.5	4437333	43B555h

Note: Carrier Freq: $CARFQ1(dec) \cdot Fs / 2^{24}$ with $Fs = 24.576$ MHz (crystal oscillator frequency independent)

FIR1C[0:7]

Channel 1 FIR Coefficients

Address (hex): 15h to 1Ch

Type: R/W

Bit 7 Bit 6 Bit 5 Bit 4 Bit 3 Bit 2 Bit 1 Bit 0

FIR1C0[7:0] to FIR1C7[7:0]

Bitfield	Description					
	FM 27 kHz	FM 50 kHz	FM 200 kHz	FM 350 kHz	FM 500 kHz	AM
FIR1C0[7:0]	FFh	00h	00h	02h	01h	00h
FIR1C1[7:0]	FEh	FEh	01h	01h	00h	FEh
FIR1C2[7:0]	FEh	FCh	01h	FCh	04h	FDh
FIR1C3[7:0]	00h	FDh	FCh	03h	FAh	FEh
FIR1C4[7:0]	06h	02h	08h	04h	05h	04h

Bitfield	Description					
FIR1C5[7:0]	0Eh	0Dh	F6h	F2h	00h	0Dh
FIR1C6[7:0]	16h	18h	F8h	06h	F2h	16h
FIR1C7[7:0]	1Bh	1Fh	4Ah	43h	4Dh	1Dh

ACOEFF1**Channel 1 Baseband PLL Loop Filter Proportional Coefficient**

Address (hex): 1Dh

Type: R/W

Bit 7	Bit 6	Bit 5	Bit 4	Bit 3	Bit 2	Bit 1	Bit 0
ACOEFF1[7:0]							

Bit Name	Reset	Function
ACOEFF1[7:0]	00100011	Used to program the Proportional Coefficient of the baseband PLL loop filter (Channel 1) Defines the damping factor of the loop. For values, refer to Table 12 .

BCOEFF1**Channel 1 Baseband PLL Loop Filter Integral Coefficient & DCO Gain**

Address (hex): 1Eh

Type: R/W

Bit 7	Bit 6	Bit 5	Bit 4	Bit 3	Bit 2	Bit 1	Bit 0
BCOEFF1[7:0]							

Bit Name	Reset	Function
BCOEFF1[7:0]	00010010	Used to program the Integral Coefficient of the baseband PLL loop filter and DCO gain Defines the bandwidth of the loop. For values, refer to Table 12 .

Table 12: Baseband PLL Loop Filter Adjustment (FM Mode)

FM Mode	Small	Standard	Medium	Large	A2 Standard
ACOEFF (hex)	10h	22h	2Ch	2Ch	10h
BCOEFF (hex)	1Ah	12h	0Ah	0Ah	11h
FM_DEV max (kHz)	62.5	125	250	500	125
DCO Range (kHz)	96	192	384	768	192

CRF1**Channel 1 Baseband PLL Demodulator Offset**

Address (hex): 1Fh

Type: R

Bit 7 Bit 6 Bit 5 Bit 4 Bit 3 Bit 2 Bit 1 Bit 0

CRF1[7:0]

Bit Name	Reset	Function
CRF1[7:0]	00000000	Channel 1 Carrier Recovery Frequency Displays the instantaneous frequency offset of the Channel 1 Baseband PLL Demodulator.

CETH1**Channel 1 FM/AM Carrier Level Threshold**

Address (hex): 20h

Type: R/W

Bit 7 Bit 6 Bit 5 Bit 4 Bit 3 Bit 2 Bit 1 Bit 0

CETH1[7:0]

Bit Name	Reset	Function																				
CETH1[7:0]	00100000	<p>This register is used to compare the carrier level in the channel and the threshold value. This level is measured after the channel filter and is relative to the full scale reference level (0 dB). This is used as part of the validation of an FM signal, if the carrier level is below the threshold, the signal is considered to be non-valid.</p> <table border="1"> <thead> <tr> <th>CETH</th> <th>Threshold (dB)</th> <th>CETH</th> <th>Threshold (dB)</th> </tr> </thead> <tbody> <tr> <td>FFh</td> <td>-6</td> <td>10h</td> <td>-32 (Recommended Value)</td> </tr> <tr> <td>80h</td> <td>-12</td> <td>08h</td> <td>-38</td> </tr> <tr> <td>40h</td> <td>-18</td> <td>00h</td> <td>OFF (all carrier levels are accepted)</td> </tr> <tr> <td>20h</td> <td>-24 (Default)</td> <td></td> <td></td> </tr> </tbody> </table>	CETH	Threshold (dB)	CETH	Threshold (dB)	FFh	-6	10h	-32 (Recommended Value)	80h	-12	08h	-38	40h	-18	00h	OFF (all carrier levels are accepted)	20h	-24 (Default)		
CETH	Threshold (dB)	CETH	Threshold (dB)																			
FFh	-6	10h	-32 (Recommended Value)																			
80h	-12	08h	-38																			
40h	-18	00h	OFF (all carrier levels are accepted)																			
20h	-24 (Default)																					

SQTH1**Channel 1 FM Squelch Threshold Register**

Address (hex): 21h

Type: R/W

Bit 7 Bit 6 Bit 5 Bit 4 Bit 3 Bit 2 Bit 1 Bit 0

SQTH1[7:0]

Bit Name	Reset	Function												
SQTH1[7:0]	00111100	<p>The squelch detector measures the level of high frequency noise (> 40 kHz) and compares it to the threshold level (SQTH). If the level is below this value, the S/N of the FM signal is considered to be acceptable. Values are given for FM with standard deviation.</p> <table border="1"> <thead> <tr> <th>SQTH</th> <th>S/N (dB)</th> </tr> </thead> <tbody> <tr> <td>FAh</td> <td>0</td> </tr> <tr> <td>77h</td> <td>10</td> </tr> <tr> <td>3Ch</td> <td>15 (Default)</td> </tr> <tr> <td>23h</td> <td>20</td> </tr> <tr> <td>19h</td> <td>25</td> </tr> </tbody> </table>	SQTH	S/N (dB)	FAh	0	77h	10	3Ch	15 (Default)	23h	20	19h	25
SQTH	S/N (dB)													
FAh	0													
77h	10													
3Ch	15 (Default)													
23h	20													
19h	25													

CAROFFSET1**Channel 1 DCO Carrier Offset Compensation**

Address (hex): 22h

Type: R/W

Bit 7	Bit 6	Bit 5	Bit 4	Bit 3	Bit 2	Bit 1	Bit 0
CAROFFSET1[7:0] (S)							

Bit Name	Reset	Function
CAROFFSET1[7:0]	00000000	<p>This value is used correct the carrier frequency offset of the incoming IF signal. Automatic frequency control in FM mode can be implemented by registers FM_DCR and FM_DCL.</p> <p>A DCO frequency offset (in two's complement format) is added to the pre-programming value by AUTOTSD in the CARFQ1 registers (corresponding to the standard IF carrier frequency). The programmable carrier offset ranges from -192 kHz to +190.5 kHz with a resolution of 1.5 kHz.</p> <p>For standard FM deviation, the value displays by FM_DCL can be directly loaded in CAROFFSET1 to exactly compensate the carrier offset on Channel 1</p>

9.7 Demodulator Channel 2**IAGCR****Channel 2 Internal AGC Reference for QPSK**

Address (hex): 25h

Type: R/W

Bit 7	Bit 6	Bit 5	Bit 4	Bit 3	Bit 2	Bit 1	Bit 0
IAGC_REF[7:0]							

Bit Name	Reset	Function
IAGC_REF[7:0]	10001000	Sets the mean value of the internal AGC, used for QPSK demodulation. The default setting corresponds to half full scale amplitude at the baseband PLL input.

IAGCC**Channel 2 Internal AGC Time Constant for QPSK**

Address (hex): 26h

Type: R/W

Bit 7	Bit 6	Bit 5	Bit 4	Bit 3	Bit 2	Bit 1	Bit 0
IAGC_OFF	0	0	0	0	IAGC_CST[2:0]		

Bit Name	Reset	Function																								
IAGC_OFF	0	AGC Disable 0: Internal AGC is active 1: Internal AGC is disabled																								
Bits[6:3]	0000	Reserved.																								
IAGC_CST[2:0]	011	<p>Internal AGC Programmable Step Constant.</p> <p>These bits control the time per step (values given for QPSK mode). The default value defines the optimum trade-off between fast settling time (for the fastest NICAM identification) and the noise immunity (minimum BER degradation)</p> <p style="text-align: center;"><u>Step time (us)</u> <u>Time Response (ms)</u></p> <table border="1"> <tr><td>000</td><td>703</td><td>128</td></tr> <tr><td>001</td><td>352</td><td>64</td></tr> <tr><td>010</td><td>176</td><td>32</td></tr> <tr><td>011</td><td>88</td><td>16</td></tr> <tr><td>100</td><td>44</td><td>8</td></tr> <tr><td>101</td><td>22</td><td>4</td></tr> <tr><td>110</td><td>11</td><td>2</td></tr> <tr><td>111</td><td>5.5</td><td>0.82</td></tr> </table>	000	703	128	001	352	64	010	176	32	011	88	16	100	44	8	101	22	4	110	11	2	111	5.5	0.82
000	703	128																								
001	352	64																								
010	176	32																								
011	88	16																								
100	44	8																								
101	22	4																								
110	11	2																								
111	5.5	0.82																								

IAGCS**Channel 2 Internal AGC Status for QPSK**

Address (hex): 27h

Type: R

Bit 7	Bit 6	Bit 5	Bit 4	Bit 3	Bit 2	Bit 1	Bit 0
IAGC_CTRL[7:0]							

Bit Name	Reset	Function
IAGC_CTRL[7:0]	00000000	Indicates the value of the internal AGC gain control

CARFQ2H, CARFQ2M, CARFQ2L Channel 2 Carrier DCO Frequency

Address (hex): 28H to 2Ah

Type: R/W

Bit 7	Bit 6	Bit 5	Bit 4	Bit 3	Bit 2	Bit 1	Bit 0
CARFQ2[23:16], CARFQ2[15:8], CARFQ2[7:0]							

Bit Name	Reset	Function
CARFQ2[23:16]	01000100	Channel 2 DCO Carrier Frequency (8 MSBs)
CARFQ2[15:8]	01000000	Channel 2 DCO Carrier Frequency
CARFQ2[7:0]	00000000	Channel 2 DCO Carrier Frequency (8 LSBs) See Table 13 .

Table 13: Stereo Carrier Frequencies by System

System	Stereo Carrier Freq. (MHz)	CARFQ2[23:0] (Dec)	CARFQ2[23:0] (Hex)
M/N A2+	4.724212	3225062	3135E6h
B/G NICAM	5.85	3993600	3CF000h
BG A2	5.7421875	3920000	3BD080h
I NICAM	6.552	4472832	444000h
L NICAM	5.85	3993600	3CF000h
DK NICAM	5.85	3993600	3CF000h
DK1 A2*	6.258125	4272000	412F80h
DK2 A2*	6.7421875	4602667	463B2Bh
DK3 A2*	5.7421875	3920000	3BD080h

FIR2C[0:7]**Channel 2 FIR Coefficients**

Address (hex): 2Bh to 32h

Type: R/W

Bit 7	Bit 6	Bit 5	Bit 4	Bit 3	Bit 2	Bit 1	Bit 0
FIR2C0[7:0] to FIR2C7[7:0]							

Table 14: Channel 2 FIR Coefficients

Bitfield	Description			
	FM 27 kHz	FM 50 kHz	QPSK 40%	QPSK100%
FIR2C0[7:0]	FFh	00h	00h	00h
FIR2C1[7:0]	FEh	FEh	00h	00h
FIR2C2[7:0]	FEh	FCh	FFh	00h
FIR2C3[7:0]	00h	FDh	03h	00h
FIR2C4[7:0]	06h	02h	00h	FFh
FIR2C5[7:0]	0Eh	0Dh	F4h	04h
FIR2C6[7:0]	16h	18h	0Ah	14h
FIR2C7[7:0]	1Bh	1Fh	3Dh	25h

ACOEFF2**Channel 2 Baseband PLL Loop Filter Proportional Coefficient**

Address (hex): 33h

Type: R/W

Bit 7 Bit 6 Bit 5 Bit 4 Bit 3 Bit 2 Bit 1 Bit 0

ACOEFF2[7:0]

Bit Name	Reset	Function
ACOEFF2[7:0]	10010000	This value defines the loop clamping factor used to program the Proportional Coefficient of the baseband PLL loop filter (Channel 2). See Table 15 and Table 16 .

BCOEFF2**Channel 2 Baseband PLL Loop Filter Integral Coefficient & DCO Gain**

Address (hex): 34h

Type: R/W

Bit 7 Bit 6 Bit 5 Bit 4 Bit 3 Bit 2 Bit 1 Bit 0

BCOEFF2[7:0]

Bit Name	Reset	Function
BCOEFF2[7:0]	10101100	This value defines the loop bandwidth used to program the Integral Coefficient of the Baseband PLL loop filter and DCO gain. See Table 15 and Table 16 .

Table 15: Baseband PLL Loop Filter Adjustments (FM Mode)

FM mode	Small	Standard	Mid	Wide	A2 standard
ACOEFF (hex)	10h	22h	2Ch	2Ch	10h
BCOEFF (hex)	1Ah	12h	0Ah	0Ah	11h
FM_DEV max (kHz)	62.5	125	250	500	125
DCO Range (kHz)	96	192	384	768	192

Table 16: Baseband PLL Loop Filter Adjustments (QPSK Mode)

QPSK mode	Small	Medium	Large	Extra-large
ACOEFF (hex)	90h	90h	90h	90h
BCOEFF (hex)	ACh	A3h	9Ah	91h
DCO_DEV max (kHz)	2.84375	5.6875	11.375	22.75

SCOEFF**Channel 2 Symbol Tracking Loop Coefficients**

Address (hex): 35h

Type: R/W

Bit 7 Bit 6 Bit 5 Bit 4 Bit 3 Bit 2 Bit 1 Bit 0

SCOEFF[7:0]

Bit Name	Reset	Function
SCOEFF[7:0]	00011100	This value is used to program the proportional and integral coefficients of the QPSK Symbol tracking loop. See Table 17 and Table 18 .

Table 17: QPSK System - BG/L/DK Standards (40% Roll-off)

	Extra-Small	Small	Medium	Large	Extra-Large	Open Loop
SCOEFF (hex)	1Eh	25h	24h	26h	2Ah	80h

Table 18: QPSK System - I Standard (100% Roll-off)

	Extra-Small	Small	Medium	Large	Extra-Large
SCOEFF (hex)	16h	1Dh	1Ch	23h	22h

SRF**Channel 2 Symbol Tracking Loop Frequency**

Address (hex): 36h

Type: R/W

Bit 7 Bit 6 Bit 5 Bit 4 Bit 3 Bit 2 Bit 1 Bit 0

SRF[7:0]

Bit Name	Reset	Function
SRF[7:0]	00000000	Displays in two's complement format the frequency deviation between the incoming NICAM bitstream and the quartz clocks. The maximum error is ± 250 ppm.

CRF2**Channel 2 Baseband PLL Demodulator Offset**

Address (hex): 37h

Type: R

Bit 7 Bit 6 Bit 5 Bit 4 Bit 3 Bit 2 Bit 1 Bit 0

CRF2[7:0]

Bit Name	Reset	Function
CRF2[7:0]	00000000	Channel 2 Carrier Recovery Frequency. Displays the instantaneous frequency offset of the Channel 2 Baseband PLL

CETH2**Channel 2 FM Carrier Level Threshold**

Address (hex): 38h

Type: R/W

Bit 7 Bit 6 Bit 5 Bit 4 Bit 3 Bit 2 Bit 1 Bit 0

CETH2[7:0]

Bit Name	Reset	Function																				
CETH2[7:0]	00100000	This register is used to compare the carrier level in the channel and the threshold value. This level is measured after the channel filter and is relative to the full scale reference level (0 dB). This is used as part of the validation of an FM signal, if the carrier level is below the threshold, the signal is considered to be non-valid. <table border="1"> <thead> <tr> <th><u>CETH</u></th> <th><u>Threshold (dB)</u></th> <th><u>CETH</u></th> <th><u>Threshold (dB)</u></th> </tr> </thead> <tbody> <tr> <td>FFh</td> <td>-6</td> <td>10h</td> <td>-32</td> </tr> <tr> <td>80h</td> <td>-12</td> <td>08h</td> <td>-38</td> </tr> <tr> <td>40h</td> <td>-18</td> <td>00h</td> <td>OFF (All carrier levels are accepted)</td> </tr> <tr> <td>20h</td> <td>-24 (Default)</td> <td></td> <td></td> </tr> </tbody> </table>	<u>CETH</u>	<u>Threshold (dB)</u>	<u>CETH</u>	<u>Threshold (dB)</u>	FFh	-6	10h	-32	80h	-12	08h	-38	40h	-18	00h	OFF (All carrier levels are accepted)	20h	-24 (Default)		
<u>CETH</u>	<u>Threshold (dB)</u>	<u>CETH</u>	<u>Threshold (dB)</u>																			
FFh	-6	10h	-32																			
80h	-12	08h	-38																			
40h	-18	00h	OFF (All carrier levels are accepted)																			
20h	-24 (Default)																					

SQTH2**Channel 2 FM Squelch Threshold**

Address (hex): 39h

Type: R/W

Bit 7 Bit 6 Bit 5 Bit 4 Bit 3 Bit 2 Bit 1 Bit 0

SQTH2[7:0]

Bit Name	Reset	Function												
SQTH2[7:0]	00111100	The squelch detector measures the level of high frequency noise (> 40 kHz) and compares it to the threshold level (SQTH). If the level is below this value, the S/N of the FM signal is considered to be acceptable. Values are given for FM with standard deviation. <table border="1"> <thead> <tr> <th><u>SQTH</u></th> <th><u>S/N (dB)</u></th> </tr> </thead> <tbody> <tr> <td>FAh</td> <td>0</td> </tr> <tr> <td>77h</td> <td>10</td> </tr> <tr> <td>3Ch</td> <td>15 (Default)</td> </tr> <tr> <td>23h</td> <td>20</td> </tr> <tr> <td>19h</td> <td>25</td> </tr> </tbody> </table>	<u>SQTH</u>	<u>S/N (dB)</u>	FAh	0	77h	10	3Ch	15 (Default)	23h	20	19h	25
<u>SQTH</u>	<u>S/N (dB)</u>													
FAh	0													
77h	10													
3Ch	15 (Default)													
23h	20													
19h	25													

CAROFFSET2**Channel 2 DCO Carrier Offset Compensation**

Address (hex): 3Ah

Type: R/W

Bit 7 Bit 6 Bit 5 Bit 4 Bit 3 Bit 2 Bit 1 Bit 0

CAROFFSET2[7:0] (S)

Bit Name	Reset	Function
CAROFFSET2 [7:0]	00000000	<p>This value is used to correct the carrier frequency offset of the incoming IF signal. Automatic frequency control in FM mode can be implemented by registers FM_DCR and FM_DCL.</p> <p>A DCO frequency offset (in two's complement format) is added to the pre-programming value by AUTOTSD in the CARFQ2 registers (corresponding to the standard IF carrier frequency). The programmable carrier offset ranges from -192 kHz to +190.5 kHz with a resolution of 1.5 kHz.</p> <p>For standard FM deviation, the value displayed by register FM_DCR can be directly loaded in in register CAROFFSET2 to exactly compensate the carrier offset on Channel 2.</p>

9.8 NICAM Registers**NICAM_CTRL****NICAM Decoder Control Register**

Address (hex): 3Dh

Type: R/W

Bit 7 Bit 6 Bit 5 Bit 4 Bit 3 Bit 2 Bit 1 Bit 0

0 0 0 0 0 DIF_POL ECT MAE

Bit Name	Reset	Function
Bits[7:3]	00000	Reserved.
DIF_POL	0	0: No polarity inversion (Default) 1: Polarity inversion of the differential decoding
ECT	0	Error Counter Timer: Defines the NICAM error measurement period 0: 128 ms (Default) 1: 64 ms
MAE	0	Max. Allowed Errors. Defines the NICAM error decoding for mute function. 0: 511 Max (Default) 1: 255 Max

NICAM_BER**NICAM Bit Error Rate Register**

Address (hex): 3Eh

Type: R

Bit 7	Bit 6	Bit 5	Bit 4	Bit 3	Bit 2	Bit 1	Bit 0
ERROR[7:0]							

Bit Name	Reset	Function
ERROR[7:0]	00000000	NICAM Error Counter Value

NICAM_STAT**NICAM Detection Status Register**

Address (hex): 3Fh

Type: R

Bit 7	Bit 6	Bit 5	Bit 4	Bit 3	Bit 2	Bit 1	Bit 0
NIC_DET	F_MUTE	LOA	CBI[3:0]			NIC_MUTE	

Bit Name	Reset	Function
NIC_DET	0	NICAM Signal Detect 0: NICAM signal no detected 1: NICAM signal detected
F_MUTE	0	Frame Mute 0: No mute 1: Mute due to Superframe Alignment Loss
LOA	0	Loss of Frame Alignment Word (FAW) 0: No Alignment Lost 1: Frame Alignment Word Lost
CBI[3:0]	0000	Indicates the received NICAM control bits
NIC_MUTE	0	Indicates the NICAM decoder mute

9.9 Zweiton**ZWT_CTRL****Zweiton Detector Control Register**

Address (hex): 40h

Type: R/W

Bit 7	Bit 6	Bit 5	Bit 4	Bit 3	Bit 2	Bit 1	Bit 0
0	STD_MODE	THRESH[3:0]			TSCTRL[1:0]		

Bit Name	Reset	Function																																				
Bit 7	0	Reserved.																																				
STD_MODE	0	0: German standard (Default) 1: Korean standard																																				
THRESH[3:0]	1100	Defines the threshold of the detector for pilot and tone frequencies. <table style="width: 100%; border-collapse: collapse;"> <thead> <tr> <th colspan="2" style="text-align: center;"><u>Level</u> (% of the mid scale)</th> <th colspan="2" style="text-align: center;"><u>Level</u> (% of the mid scale)</th> </tr> </thead> <tbody> <tr> <td>0000</td> <td style="text-align: center;">0</td> <td>1000</td> <td style="text-align: center;">50</td> </tr> <tr> <td>0001</td> <td style="text-align: center;">6.25</td> <td>1001</td> <td style="text-align: center;">56.25</td> </tr> <tr> <td>0010</td> <td style="text-align: center;">12.5</td> <td>1010</td> <td style="text-align: center;">62.5</td> </tr> <tr> <td>0011</td> <td style="text-align: center;">18.75</td> <td>1011</td> <td style="text-align: center;">68.75</td> </tr> <tr> <td>0100</td> <td style="text-align: center;">25</td> <td>1100 (Default)</td> <td style="text-align: center;">75</td> </tr> <tr> <td>0101</td> <td style="text-align: center;">31.25</td> <td>1101</td> <td style="text-align: center;">81.25</td> </tr> <tr> <td>0110</td> <td style="text-align: center;">37.5</td> <td>1110</td> <td style="text-align: center;">87.5</td> </tr> <tr> <td>0111</td> <td style="text-align: center;">43.75</td> <td>1111</td> <td style="text-align: center;">93.75</td> </tr> </tbody> </table>	<u>Level</u> (% of the mid scale)		<u>Level</u> (% of the mid scale)		0000	0	1000	50	0001	6.25	1001	56.25	0010	12.5	1010	62.5	0011	18.75	1011	68.75	0100	25	1100 (Default)	75	0101	31.25	1101	81.25	0110	37.5	1110	87.5	0111	43.75	1111	93.75
<u>Level</u> (% of the mid scale)		<u>Level</u> (% of the mid scale)																																				
0000	0	1000	50																																			
0001	6.25	1001	56.25																																			
0010	12.5	1010	62.5																																			
0011	18.75	1011	68.75																																			
0100	25	1100 (Default)	75																																			
0101	31.25	1101	81.25																																			
0110	37.5	1110	87.5																																			
0111	43.75	1111	93.75																																			
TSCTRL[1:0]	00	Defines both the detection time and the error probability (reliability of the detection). <table style="width: 100%; border-collapse: collapse;"> <thead> <tr> <th></th> <th style="text-align: center;"><u>Sample Accumulation</u></th> <th style="text-align: center;"><u>Decision Count</u></th> <th style="text-align: center;"><u>Time (ms)</u></th> <th style="text-align: center;"><u>Error Probability</u></th> </tr> </thead> <tbody> <tr> <td>00</td> <td style="text-align: center;">1024</td> <td style="text-align: center;">2</td> <td style="text-align: center;">256</td> <td style="text-align: center;">10^{-4}</td> </tr> <tr> <td>01 (Default)</td> <td style="text-align: center;">1024</td> <td style="text-align: center;">3</td> <td style="text-align: center;">384</td> <td style="text-align: center;">10^{-6}</td> </tr> <tr> <td>10</td> <td style="text-align: center;">2048</td> <td style="text-align: center;">2</td> <td style="text-align: center;">512</td> <td style="text-align: center;">10^{-7}</td> </tr> <tr> <td>11</td> <td style="text-align: center;">2048</td> <td style="text-align: center;">3</td> <td style="text-align: center;">768</td> <td style="text-align: center;">10^{-9}</td> </tr> </tbody> </table>		<u>Sample Accumulation</u>	<u>Decision Count</u>	<u>Time (ms)</u>	<u>Error Probability</u>	00	1024	2	256	10^{-4}	01 (Default)	1024	3	384	10^{-6}	10	2048	2	512	10^{-7}	11	2048	3	768	10^{-9}											
	<u>Sample Accumulation</u>	<u>Decision Count</u>	<u>Time (ms)</u>	<u>Error Probability</u>																																		
00	1024	2	256	10^{-4}																																		
01 (Default)	1024	3	384	10^{-6}																																		
10	2048	2	512	10^{-7}																																		
11	2048	3	768	10^{-9}																																		

ZWT_STAT**Zweiton Status Register**

Address (hex): 41h

Type: R

Bit 7	Bit 6	Bit 5	Bit 4	Bit 3	Bit 2	Bit 1	Bit 0
0	0	0	0	0	ZW_DET	ZW_ST	ZW_DM

Bit Name	Reset	Function
Bits[7:3]	00000	Reserved.
ZW_DET	0	Pilot Detection Flag
ZW_ST	0	Stereo Tone Detection Flag
ZW_DM	0	Dual Mono Tone Detection Flag

9.10 Sound Preprocessing and Selection Registers**FM_DCL****FM DC Offset Left Register**

Address (hex): 42h

Type: R

Bit 7	Bit 6	Bit 5	Bit 4	Bit 3	Bit 2	Bit 1	Bit 0
FM_DCL[7:0]							

Bit Name	Reset	Function
FM_DCL[7:0]	00000000	Displays (in two's complement format) the FM (or AM) DC offset level after demodulation on channel 1 (and removed automatically). In FM mode, the DC offset value gives a direct value of the carrier frequency offset which is used to compensate the DCO with the CAROFFSET1 value in the event of an out-of-standard offset. The range and the resolution depend upon the FM bandwidth programmed defined in register BCOEFF1. See Table 19 .

FM_DCR**FM DC Offset Right Register**

Address (hex): 43h

Type: R

Bit 7	Bit 6	Bit 5	Bit 4	Bit 3	Bit 2	Bit 1	Bit 0
FM_DCR[7:0]							

Bit Name	Reset	Function
FM_DCR[7:0]	00000000	Displays (in two's complement format) the FM (or AM) DC offset level after demodulation on channel 2 (and removed automatically). In FM mode, the DC offset value gives a direct value of the carrier frequency offset which is used to compensate the DCO with the CAROFFSET2 value in the event of an out-of-standard offset. The range and the resolution depend upon the FM bandwidth programmed defined in register BCOEFF2. See Table 19 .

Table 19: FM_DCL/R Range and Resolution

FM mode	Range (kHz)	Resolution (kHz)
Small	± 96	0.750
Standard & A2 Standard	± 192	1.5
Medium	± 384	3
Large	± 768	6

PRE_FM**FM Prescaling Register**

Address (hex): 44h

Type: R/W

Bit 7	Bit 6	Bit 5	Bit 4	Bit 3	Bit 2	Bit 1	Bit 0
0	0	FM_PRESCALE[5:0]					

Bit Name	Reset	Function
Bits[7:6]	0	Reserved.

Bit Name	Reset	Function																												
FM_PRESCALE [5:0]	000110	-6 to + 24 dB FM (or AM) prescaling to normalize the FM (or AM) demodulated signal level before audio processing. Auto level control can be implemented by I ² C software using the Peak Level Detector. (Default value = +6 dB)																												
		<table> <thead> <tr> <th></th> <th><u>G (dB)</u></th> <th></th> <th><u>G (dB)</u></th> </tr> </thead> <tbody> <tr> <td>011000</td> <td>+24</td> <td>111110</td> <td>-2</td> </tr> <tr> <td>010111</td> <td>+23</td> <td>111101</td> <td>-3</td> </tr> <tr> <td>010110</td> <td>+22</td> <td>111100</td> <td>-4</td> </tr> <tr> <td>010101</td> <td>+21</td> <td>111011</td> <td>-5</td> </tr> <tr> <td>010100</td> <td>+20</td> <td>111010</td> <td>-6</td> </tr> <tr> <td></td> <td>etc.</td> <td></td> <td></td> </tr> </tbody> </table>		<u>G (dB)</u>		<u>G (dB)</u>	011000	+24	111110	-2	010111	+23	111101	-3	010110	+22	111100	-4	010101	+21	111011	-5	010100	+20	111010	-6		etc.		
	<u>G (dB)</u>		<u>G (dB)</u>																											
011000	+24	111110	-2																											
010111	+23	111101	-3																											
010110	+22	111100	-4																											
010101	+21	111011	-5																											
010100	+20	111010	-6																											
	etc.																													

PRE_NICAM**NICAM Prescaling Register**

Address (hex): 45h

Type: R/W

Bit 7	Bit 6	Bit 5	Bit 4	Bit 3	Bit 2	Bit 1	Bit 0
0	0	NICAM_PRESCALE[5:0]					

Bit Name	Reset	Function																												
Bits[7:6]	00	Reserved.																												
NICAM_ PRESCALE[5:0]	001101	-6 to + 24 dB NICAM prescaling to normalize the NICAM demodulated signal level before audio processing. Auto level control can be implemented by I ² C software using the Peak Level Detector. (Default value = +13 dB)																												
		<table> <thead> <tr> <th></th> <th><u>G (dB)</u></th> <th></th> <th><u>G (dB)</u></th> </tr> </thead> <tbody> <tr> <td>011000</td> <td>+24</td> <td>111110</td> <td>-2</td> </tr> <tr> <td>010111</td> <td>+23</td> <td>111101</td> <td>-3</td> </tr> <tr> <td>010110</td> <td>+22</td> <td>111100</td> <td>-4</td> </tr> <tr> <td>010101</td> <td>+21</td> <td>111011</td> <td>-5</td> </tr> <tr> <td>010100</td> <td>+20</td> <td>111010</td> <td>-6</td> </tr> <tr> <td></td> <td>etc.</td> <td></td> <td></td> </tr> </tbody> </table>		<u>G (dB)</u>		<u>G (dB)</u>	011000	+24	111110	-2	010111	+23	111101	-3	010110	+22	111100	-4	010101	+21	111011	-5	010100	+20	111010	-6		etc.		
	<u>G (dB)</u>		<u>G (dB)</u>																											
011000	+24	111110	-2																											
010111	+23	111101	-3																											
010110	+22	111100	-4																											
010101	+21	111011	-5																											
010100	+20	111010	-6																											
	etc.																													

PRE_AUX**SCART Prescaling Register**

Address (hex): 46h

Type: R/W

Bit 7	Bit 6	Bit 5	Bit 4	Bit 3	Bit 2	Bit 1	Bit 0
I2S_PRESCALE[3:0]				SCART_PRESCALE[3:0]			

Bit Name	Reset	Function																																
I2S_PRESCALE [3:0]	0000	-6 to +6dB I ² S Input prescaling to normalize the incoming audio signal before audio processing. Auto level control can be implemented by I ² C software using the Peak Level Detector. These bits are used to adjust the corresponding incoming signal level before audio processing. <table style="margin-left: auto; margin-right: auto;"> <thead> <tr> <th></th> <th><u>G (dB)</u></th> <th></th> <th><u>G (dB)</u></th> </tr> </thead> <tbody> <tr> <td>0110</td> <td>+6</td> <td>1111</td> <td>-1</td> </tr> <tr> <td>0101</td> <td>+5</td> <td>1110</td> <td>-2</td> </tr> <tr> <td>0100</td> <td>+4</td> <td>1101</td> <td>-3</td> </tr> <tr> <td>0011</td> <td>+3</td> <td>1100</td> <td>-4</td> </tr> <tr> <td>0010</td> <td>+2</td> <td>1011</td> <td>-5</td> </tr> <tr> <td>0001</td> <td>+1</td> <td>1010</td> <td>-6</td> </tr> <tr> <td>0000 (Default)</td> <td>0</td> <td></td> <td></td> </tr> </tbody> </table>		<u>G (dB)</u>		<u>G (dB)</u>	0110	+6	1111	-1	0101	+5	1110	-2	0100	+4	1101	-3	0011	+3	1100	-4	0010	+2	1011	-5	0001	+1	1010	-6	0000 (Default)	0		
	<u>G (dB)</u>		<u>G (dB)</u>																															
0110	+6	1111	-1																															
0101	+5	1110	-2																															
0100	+4	1101	-3																															
0011	+3	1100	-4																															
0010	+2	1011	-5																															
0001	+1	1010	-6																															
0000 (Default)	0																																	
SCART_PRESCALE E[3:0]	0000	-6 to +6dB SCART Input prescaling to normalize the incoming audio signal before audio processing. Auto level control can be implemented by I ² C software using the Peak Level Detector. These bits are used to adjust the corresponding incoming signal level before audio processing. <table style="margin-left: auto; margin-right: auto;"> <thead> <tr> <th></th> <th><u>G (dB)</u></th> <th></th> <th><u>G (dB)</u></th> </tr> </thead> <tbody> <tr> <td>0110</td> <td>+6</td> <td>1111</td> <td>-1</td> </tr> <tr> <td>0101</td> <td>+5</td> <td>1110</td> <td>-2</td> </tr> <tr> <td>0100</td> <td>+4</td> <td>1101</td> <td>-3</td> </tr> <tr> <td>0011</td> <td>+3</td> <td>1100</td> <td>-4</td> </tr> <tr> <td>0010</td> <td>+2</td> <td>1011</td> <td>-5</td> </tr> <tr> <td>0001</td> <td>+1</td> <td>1010</td> <td>-6</td> </tr> <tr> <td>0000 (Default)</td> <td>0</td> <td></td> <td></td> </tr> </tbody> </table>		<u>G (dB)</u>		<u>G (dB)</u>	0110	+6	1111	-1	0101	+5	1110	-2	0100	+4	1101	-3	0011	+3	1100	-4	0010	+2	1011	-5	0001	+1	1010	-6	0000 (Default)	0		
	<u>G (dB)</u>		<u>G (dB)</u>																															
0110	+6	1111	-1																															
0101	+5	1110	-2																															
0100	+4	1101	-3																															
0011	+3	1100	-4																															
0010	+2	1011	-5																															
0001	+1	1010	-6																															
0000 (Default)	0																																	

CH_CTRL**Channel Control Register**

Address (hex): 47h

Type: R/W

Bit 7	Bit 6	Bit 5	Bit 4	Bit 3	Bit 2	Bit 1	Bit 0
MUTE_D012	MUTE_D12	NIC_DMXX	NICDPH_OFF	FM_DMXX[1:0]	FMDPH_OFF	FMDPH_SW	

Bit Name	Reset	Function															
MUTE_D012	0	0: LS/HP/SC/I ² S channel unmuted 1: If DEMOD source is selected as OUTPUT channel by CH_SEL and CH_LANG, then MUTE_LS/MUTE_HP/MUTE_SC signal are set (LS/HP/SC/I ² S channel mute)															
MUTE_D12	0	0: LS/HP/SC/I ² S channel unmuted 1: If DEMOD_1 or DEMOD_2 source is selected as OUTPUT channel by CH_SEL and CH_LANG, then MUTE_LS/MUTE_HP/MUTE_SC signal are set (LS/HP/SC/I ² S channel mute)															
NIC_DMXX	0	When 1, Reverse Left/Right Channel to take into account the case where the mono signal would be carried on the Right Channel.															
NICDPH_OFF	0	0: NICAM De-emphasis (Default) 1: Bypass NICAM De-emphasis															
FM_DMXX[1:0]	00	FM Stereo Dematrix <table style="margin-left: auto; margin-right: auto;"> <thead> <tr> <th></th> <th><u>DeMatrix</u></th> <th><u>Standard</u></th> </tr> </thead> <tbody> <tr> <td>00 (Default)</td> <td>L=CH1, R=CH2</td> <td>No matrixing</td> </tr> <tr> <td>01</td> <td>L=CH1+CH2, R=CH1-CH2</td> <td>Kor. Zweiton (A2+) & Radio</td> </tr> <tr> <td>10</td> <td>L=2CH1-CH2, R=CH2</td> <td>German Zweiton (A2, A2*)</td> </tr> <tr> <td>11</td> <td>L=(CH1+CH2)/2, R=(CH1+CH2)/2</td> <td>Stereo to Mono</td> </tr> </tbody> </table>		<u>DeMatrix</u>	<u>Standard</u>	00 (Default)	L=CH1, R=CH2	No matrixing	01	L=CH1+CH2, R=CH1-CH2	Kor. Zweiton (A2+) & Radio	10	L=2CH1-CH2, R=CH2	German Zweiton (A2, A2*)	11	L=(CH1+CH2)/2, R=(CH1+CH2)/2	Stereo to Mono
	<u>DeMatrix</u>	<u>Standard</u>															
00 (Default)	L=CH1, R=CH2	No matrixing															
01	L=CH1+CH2, R=CH1-CH2	Kor. Zweiton (A2+) & Radio															
10	L=2CH1-CH2, R=CH2	German Zweiton (A2, A2*)															
11	L=(CH1+CH2)/2, R=(CH1+CH2)/2	Stereo to Mono															

Bit Name	Reset	Function
FMDPH_OFF	0	0: FM De-emphasis (Default) 1: Bypass FM De-emphasis
FMDPH_SW	0	0: 50 μ s FM De-emphasis (Default) 1: 75 μ s FM De-emphasis

CH_MX**Channel Matrix Register**

Address (hex): 48h

Type: R/W

Bit 7	Bit 6	Bit 5	Bit 4	Bit 3	Bit 2	Bit 1	Bit 0
I2S_MX[1:0]		SC_MX[1:0]		DEMOD_MX[3:0]			

Bit Name	Reset	Function
I2S_MX[1:0]	00	I ² S Matrixing. Programmable values are listed in Table 20 .
SC_MX[1:0]	00	SCART Matrixing. Programmable values are listed in Table 20 .
DEMOD_MX[3:0]	0000	Demodulator Matrixing. Programmable values are listed in Table 21 .

Table 20: SCART and I²S Matrixing

	SC_0/I2S_0		SC_1/I2S_1	
	Left	Right	Left	Right
00	CH_L	CH_R	0	
01	CH_R	CH_L	0	
10	CH_L		CH_R	
11	CH_R		CH_L	

Table 21: Demodulator Matrixing

	DEMOD_0		DEMOD_1		DEMOD_2
	Left	Right	Left	Right	Left
0X00	FM_L		0		0
0X01	FM_L	FM_R	0		0
0X10	NIC_L	NIC_R	0		0
0X11	NIC_L		0		0
1000	FM_L		FM_R		0
1001	NIC_L		NIC_R		0
1010	FM_L		NIC_L	NIC_R	0

Table 21: Demodulator Matrixing (Continued)

	DEMOD_0		DEMOD_1		DEMOD_2
	Left	Right	Left	Right	Left
1011	FM_L		NIC_L		NIC_R
11XX	FM_L		NIC_L		0

CH_SEL**Channel Source Selection Register**

Address (hex): 49h

Type: R/W

Bit 7	Bit 6	Bit 5	Bit 4	Bit 3	Bit 2	Bit 1	Bit 0
I2S_SEL[1:0]	SC_SEL[1:0]		HP_SEL[1:0]		LS_SEL[1:0]		

Bit Name	Reset	Function
I2S_SEL[1:0]	00	Source Channel Selection. 0X: Demodulated sound (Default) 10: SCART 11: I ² S
SC_SEL[1:0]	00	
HP_SEL[1:0]	00	
LS_SEL[1:0]	00	

Note: A mute of the corresponding audio output is recommended before switching between Demodulated sound and SCART source. Any audio discontinuity might create annoying audible pops.

CH_LANG**Channel Language Selection Register**

Address (hex): 4Ah

Type: R/W

Bit 7	Bit 6	Bit 5	Bit 4	Bit 3	Bit 2	Bit 1	Bit 0
I2S_LANG[1:0]	SC_LANG[1:0]		HP_LANG[1:0]		LS_LANG[1:0]		

Bit Name	Reset	Function
I2S_LANG[1:0]	00	Channel Language Selection. See Table 4 and Table 5 . 00: Not to be used. 01: Mono A 10: Mono B 11: Mono C
SC_LANG[1:0]	00	
HP_LANG[1:0]	00	
LS_LANG[1:0]	00	

Note: 1 Refer to [Table 4](#) and [Table 5](#) for selecting Channel Language, Sound and System values.

2 A mute of the corresponding audio output is recommended before changing the language. Any audio discontinuity might create annoying audible pop.

PEAK_DET_CTRL Peak Level Detector Control Register

Address (hex): 4Bh

Type: R

Bit 7	Bit 6	Bit 5	Bit 4	Bit 3	Bit 2	Bit 1	Bit 0
0	0	0	0	0	0	PD_SEL[1:0]	

Bit Name	Reset	Function
Bits[7:2]	000000	Reserved.
PD_SEL[1:0]	00	Peak Level Detector Source Selection 00: FM 10: SCART 01: NICAM 11: I ² S

PEAK_DET_STATL Peak Level Detector Status Register

Address (hex): 4Ch

Type: R

Bit 7	Bit 6	Bit 5	Bit 4	Bit 3	Bit 2	Bit 1	Bit 0
PEAK_LEVEL_LEFT[7:0]							

Bit Name	Reset	Function
PEAK_LEVEL_LEFT[7:0]	00000000	Displays the Absolute Peak Level of the audio source selected. The measured value is updated continuously every 64 ms. The range varies linearly from the full scale (0 dB) down to 1/256 of the full scale (-48 dB). In AM/FM Mono mode, only the PEAK_LEVEL_LEFT[7:0] value must be taken into account. In FM Mono mode, the audio peak level range depends upon the programmed FM bandwidth. The unique difference is that the measurement is done after Sound pre-processing (DC offset removal, Prescaling, De-emphasis and Dematrixing). In FM Stereo mode, the maximum value may be used to check if the incoming signal level is correctly adjusted by the prescaling factor or if there are no FM overmodulation problems (clipping). Programmable values are listed in Table 19 . The difference between the PEAK_LEVEL_LEFT[7:0] and PEAK_LEVEL_RIGHT[7:0] values may be calculated by the microcontroller to identify Mono or Stereo mode from an unknown source (SCART or I ² S).

PEAK_DET_STATR **Peak Level Detector Status Register**

Address (hex): 4Dh

Type: R

Bit 7	Bit 6	Bit 5	Bit 4	Bit 3	Bit 2	Bit 1	Bit 0
PEAK_LEVEL_RIGHT[7:0]							

Bit Name	Reset	Function
PEAK_LEVEL_RIGHT[7:0]	00000000	Displays the Absolute Peak Level of the audio source selected. The measured value is updated continuously every 64 ms. The range varies linearly from the full scale (0 dB) down to 1/256 of the full scale (-48 dB). For more information, refer to register PEAK_DET_STATL .

9.11 Automatic Standard Recognition**AUTO_CTRL** **Automatic Standard Recognition Control Register**

Address (hex): 50h

Type: R/W

Bit 7	Bit 6	Bit 5	Bit 4	Bit 3	Bit 2	Bit 1	Bit 0
0	0	0	IRQ	SINGLE_SHOT	DK_DEV[1:0]	LDK_SW	

Bit Name	Reset	Function
Bits[7:5]	000	Reserved.
IRQ	0	This flag (output on IRQ pin) is set to ON by the AUTOSTD when the standard recognition status has changed. The external microprocessor will detect this signal and will run the OSD procedure. This procedure must first reset via I ² C the IRQ flag and then read the detection status in the registers (NICAM_STAT, ZWT_STAT, AUTO_STAT and CH_MX)
SINGLE_SHOT	0	Single Shot Mode Selection 0: Single Shot mode is not selected 1: Single Shot mode is selected ¹
DK_DEV[1:0]	00	Selects FM deviation configuration to take into account of overmodulation in DK_NICAM standard. 00: FM 50 kHz (Default) 10: FM 350 kHz 01: FM 200 kHz 11: FM 500 kHz
LDK_SW	1	Makes exclusive the auto search of DK/K1/K2/K3 and L/L' standard 0: DK/K1/K2/K3 standard auto-search / L/L' disabled 1: L/L' standard auto-search / DK/K1/K2/K3 disabled

1. **Single Shot mode** can be used before disabling the Automatic Standard Recognition (AUTOSTD) to pre-program demodulator registers in a defined standard and reduce I²C programming in Manual mode

Note: Only standard deviation FM 50K kHz is compatible with other D/K1/K2/K3 standards in Automatic Standard Recognition Search mode. It has to be deselected when programs with larger FM deviation are broadcast (reserved only for D/K-Mono or D/K NICAM standard).

FM deviation superior to 350 kHz will degrade strongly NICAM reception due to overlapping of FM and QPSK IF spectrum in DK-NICAM standard.

L/L' and DK/K1/K2/K3 standard can be discriminated in Automatic Standard Recognition Search mode because the same frequency is used for the mono IF carrier.

AUTO_SCKM Auto Standard Check Mono Register

Address (hex): 51h

Type: R/W

Bit 7	Bit 6	Bit 5	Bit 4	Bit 3	Bit 2	Bit 1	Bit 0
0	0	0	0	LDK_SCK	I_SCK	BG_SCK	MN_SCK

Bit Name	Reset	Function
Bits[7:4]	0000	Reserved.
LDK_SCK	1	L/L' or D/K Mono Standard Enable 0: Disabled 1: Enabled
I_SCK	1	I Mono Standard Enable 0: Disabled 1: Enabled
BG_SCK	1	B/G Mono Standard Enable 0: Disabled 1: Enabled
MN_SCK	1	M/N Mono Standard Enable 0: Disabled 1: Enabled

Note: AUTOSTD is off when all mono standards are disabled.

AUTO_SCKST Auto Standard Check Stereo Register

Address (hex): 52h

Type: R/W

Bit 7	Bit 6	Bit 5	Bit 4	Bit 3	Bit 2	Bit 1	Bit 0
LDK_ZWT3	LDK_ZWT2	LDK_SWT1	LDK_NIC	I_NIC	BG_ZWT	BG_NIC	MN_ZWT

Bit Name	Reset	Function
LDK_ZWT3	0	D/K3 Zweiton (A2*) Stereo Standard Enable 0: Disabled 1: Enabled
LDK_ZWT2	0	D/K2 Zweiton (A2*) Stereo Standard Enable 0: Disabled 1: Enabled
LDK_ZWT1	0	D/K1 Zweiton (A2*) Stereo Standard Enable 0: Disabled 1: Enabled
LDK_NIC	1	D/K NICAM Stereo Standard Enable 0: Disabled 1: Enabled
I_NIC	1	I NICAM Stereo Standard Enable 0: Disabled 1: Enabled
BG_ZWT	1	B/G Zweiton (A2) Standard Enable 0: Disabled 1: Enabled
BG_NIC	1	B/G NICAM Standard Enable 0: Disabled 1: Enabled
MN_ZWT	1	M/N Zweiton (A2+) Standard Enable 0: Disabled 1: Enabled

Note: Stereo standard covers all transmission modes (stereo or multi-language) of the NICAM or Zweiton (A2, A2* or A2+) system.

AUTO_TIMER Detection Time Out Register

Address (hex): 53h

Type: R/W

Bit 7	Bit 6	Bit 5	Bit 4	Bit 3	Bit 2	Bit 1	Bit 0
FM_TIME[1:0]		NICAM_TIME[2:0]			ZWEITON_TIME[2:0]		

Bit Name	Reset	Function
FM_TIME[1:0]	10	FM Detection Time-out 00: 16 ms 10: 48 ms (Default) 01: 32 ms 11: 64 ms
NICAM_TIME[2:0]	100	NICAM Detection Time-out 000: 96 ms 100: 224 ms (Default) 001: 128 ms 101: 256 ms 010: 160 ms 110: 288 ms 011: 192 ms 111: 320 ms

Bit Name	Reset	Function
ZWEITON_TIME[2:0]	100	Zweiton Detection Time-out 000: 256 ms 100: 1280 ms (Default) 001: 512 ms 101: 1536 ms 010: 768 ms 110: 1792 ms 011: 1024 ms 111: 2040 ms

Note: The time-out default value is optimum and does not normally need to be changed.

AUTO_STAT Detection Standard Status Register

Address (hex): 54h

Type: R

Bit 7	Bit 6	Bit 5	Bit 4	Bit 3	Bit 2	Bit 1	Bit 0
ST_ID	STEREO_STATE	MONO_STATE	AUTO_ON	STEREO_SID[1:0]		MONO_SID[1:0]	

Bit Name	Reset	Function
ST_ID	0	Stereo Mode Detection flag activated when a stereo standard coming from the demodulator selected on Loudspeaker output. Stereo transmission modes are: - Zweiton stereo (ZWT_DET&ST&DM = 110, indifferently German or Korean standard) - NICAM stereo with backup (CBI = 1000) - NICAM stereo with no backup (CBI = 0000) The stereo flag is also output on ST pin to control an external indicator (an LED, for instance)
STEREO_STATE	0	When AUTOSTD is ON and a standard has been detected, the FSM has two “stable states”. These flags indicate whether the FSM is in the state “mono-det” (mono standard detected) or “stereo-det” (stereo standard detected). If at least one stereo standard is enabled, the “mono-det” state is only transitory.
MONO_STATE	0	
AUTO_ON	0	Automatic Standard Recognition System Status 0: Automatic Standard Recognition System is OFF 1: Automatic Standard Recognition System is ON
STEREO_SID[1:0]	00	Identification of the detected TV sound standard. See Table 22 .
MONO_SID[1:0]	00	

Table 22: TV Sound Standards

System	Mono Sound (MHz)	MONO_SID [1:0]	LDK_SW	DK_DEV [1:0]	Stereo Sound (MHz)	STEREO_SID [1:0]
M/N	4.5 (FM 27k)	00	X	XX	4.724 (Zweiton A2+)	00
B/G	5.5 (FM 50k)	01	X	XX	5.85 (NICAM 40%)	00
			X	XX	5.742 (Zweiton A2)	01
I	6.0 (FM 50k)	10	X	XX	6.552 (NICAM 100%)	00

Table 22: TV Sound Standards

System	Mono Sound (MHz)	MONO_SID [1:0]	LDK_SW	DK_DEV [1:0]	Stereo Sound (MHz)	STEREO_SID [1:0]	
L	6.5 (AM)	111	1	XX	5.85 (NICAM 40%)	00	
D/K	6.5 (FM 50k)		0		00	5.85 (NICAM 40%)	00
	6.5 (FM 200k)				01		
	6.5 (FM 350k)				10		
	6.5 (FM 500k)				11		
D/K1/K2/ K3	6.5 (FM 50k)		0	XX	5.85 (NICAM 40%)	00	
			0	XX	6.258 (Zweiton A2*)	01	
			0	XX	6.742 (Zweiton A2*)	10	
			0	XX	5.742 (Zweiton A2*)	11	

9.12 Smart Volume Control

SVC_SEL

SVC Selection for Loudspeaker/Headphone Register

Address (hex): 59h

Type: R/W

Bit 7	Bit 6	Bit 5	Bit 4	Bit 3	Bit 2	Bit 1	Bit 0
0	0	0	0	0	0	0	SVC_SW

Bit Name	Reset	Function
Bit[7:1]	0000000	Reserved
SVC_SW	0	Smart Volume Control Selection 0: SVC selection on Loudspeaker path 1: SVC selection on Headphone path

SVC_CTRL

SVC Control Register

Address (hex): 5Ah

Type: R/W

Bit 7	Bit 6	Bit 5	Bit 4	Bit 3	Bit 2	Bit 1	Bit 0
SVC_ON	SVC_TIME[1:0]		SVC_REF[4:0]				

Bit Name	Reset	Function
SVC_ON	0	Smart Volume Control Mode Select 0: Prescaling (Prevents internal clipping) 1: Automatic Level Regulation (Automatically regulates the selected sound source)

Bit Name	Reset	Function
SVC_TIME[1:0]	10	Defines the constant time of the gain loop. <u>Time Constant for 6 dB Amplification</u> 00: 16 s (Default) 01: 8 s 10: 4 s 11: 2 s
SVC_REF[4:0]	00000	Smart Volume Control Reference Level Select If SVC_ON = 0, this value defines the prescaling gain ranging from -30 dB to +15.5 dB. If SVC_ON = 1, this value defines the output reference level of the regulation ranging from -2.5 dB down to -30 dB. The SVC output level must be adjusted to avoid internal clipping due to post-processing with amplification, i.e. ST/SRS™ Surround Sound (+9 dB max), Equalizer or Bass/Treble (+12 dB max) and Loudness (+6 dB max). Programmable values are listed in Table 23 .

Table 23: SVC Bit Values

SVC_ON = 0		SVC_ON = 1	
SVC_REF[4:0]	REF_LEVEL (dB)	SVC_REF[4:0]	REF_LEVEL (dB)
> 00101	Reserved	> 00101	Reserved
00101	+15.5	00101	-12
00100	+12	00100	-12
00011	+9.5	00011	-12
00010	6	00010	-12
00001	3.5	00001	-12
00000 (Default)	0	00000	-12
11111	-2.5	11111 ¹	-2.5
11110	-6	11110 ¹	-6
11101	-8.5	11101	-8.5
11100	-12	11100	-12
11011	-14.5	11011	-14.5
11010	-18	11010	-18
11001	-20.5	11001	-20.5
11000	-24	11000	-24
10111	-26.5	10111	-26.5
10110	-30	10110	-30
<10110	Reserved	< 10110	Reserved

Note: 1 When the SVC is in Automatic mode (SVC_ON = 1), internal clipping may occur with a high reference level (REF_LEVEL = -2.5 or -6 dB). The maximum recommended value is -8.5 dB.

2 A mute of the corresponding audio output is recommended before switching ON/OFF. A gain discontinuity may create annoying audible plops.

9.13 Surround

LS_SRD_CTRL

Loudspeaker Surround Control Register

Address (hex): 5Bh

Type: R/W

Bit 7	Bit 6	Bit 5	Bit 4	Bit 3	Bit 2	Bit 1	Bit 0
SRD_ON	0	0	0	0	SRD_SEL	SRD_STEREO	STS_MODE

Bit Name	Reset	Function
SRD_ON	0	Surround Sound Enable 0: Surround Sound is disabled 1: Surround Sound is enabled
Bits[6:3]	0000	Reserved
SRD_SEL	0	Surround Sound Select 0: ST WideSurround Sound (Default) 1: SRS™ Surround Sound. This option is only available if the SRS_ON bit in register CUT_ID is set. (STV8226/36 only)
SRD_STEREO	0	Surround Sound Stereo Mode 0: Surround Sound in Mono mode (Default) 1: Surround Sound in Stereo mode
STS_MODE	0	ST WideSurround Sound Mode Selection for Stereo Source Only The ST_ID bit in register AUTO_STAT must be set. 0: ST WideSurround Sound Movie mode (Default) 1: ST WideSurround Sound Music mode

LS_STS_GAIN

Loudspeaker ST WideSurround Gain Register

Address (hex): 5Ch

Type: R/W

Bit 7	Bit 6	Bit 5	Bit 4	Bit 3	Bit 2	Bit 1	Bit 0
STS_GAIN[7:0]							

Bit Name	Reset	Function																								
STS_GAIN[7:0]	10000000	Defines the ST WideSurround Sound component gain in linear scale. <table border="0"> <thead> <tr> <th></th> <th>Level (%)</th> <th></th> <th>Level (%)</th> </tr> </thead> <tbody> <tr> <td>1000 0000 (Default)</td> <td>100%</td> <td>0000 0100</td> <td>3.1%</td> </tr> <tr> <td>0111 1111</td> <td>99.2%</td> <td>0000 0011</td> <td>2.3%</td> </tr> <tr> <td>0111 1110</td> <td>98.4%</td> <td>0000 0010</td> <td>1.6%</td> </tr> <tr> <td>0111 1101</td> <td>97.6%</td> <td>0000 0001</td> <td>0.8%</td> </tr> <tr> <td>.....</td> <td></td> <td>0000 0000</td> <td>0%</td> </tr> </tbody> </table>		Level (%)		Level (%)	1000 0000 (Default)	100%	0000 0100	3.1%	0111 1111	99.2%	0000 0011	2.3%	0111 1110	98.4%	0000 0010	1.6%	0111 1101	97.6%	0000 0001	0.8%		0000 0000	0%
	Level (%)		Level (%)																							
1000 0000 (Default)	100%	0000 0100	3.1%																							
0111 1111	99.2%	0000 0011	2.3%																							
0111 1110	98.4%	0000 0010	1.6%																							
0111 1101	97.6%	0000 0001	0.8%																							
.....		0000 0000	0%																							

LS_STS_FREQ**Loudspeaker ST WideSurround Sound Frequency**

Address (hex): 5Dh

Type: R

Bit 7	Bit 6	Bit 5	Bit 4	Bit 3	Bit 2	Bit 1	Bit 0
0	0	BASS_FREQ[1:0]		MEDIUM_FREQ[1:0]		TREBLE_FREQ[1:0]	

Bit Name	Reset	Function
Bits[7:6]	00	Reserved.
BASS_FREQ[1:0]	01	Defines the bass frequency effect for ST WideSurround Sound. Programmable values are listed in Table 24 .
MEDIUM_FREQ[1:0]	01	Defines the medium frequency effect for ST WideSurround Sound in Movie or Mono mode (no effect in Music mode). Programmable values are listed in Table 24 .
TREBLE_FREQ[1:0]	01	Defines the treble frequency effect for ST WideSurround Sound in Movie or Mono mode (no effect in Music mode). Programmable values are listed in Table 24 .

Table 24: Phase Shifter Center Frequencies

	Phase Shifter Center Frequency		
	BASS_FREQ[1:0]	MEDIUM_FREQ[1:0]	TREBLE_FREQ[1:0]
00	40 Hz	202 Hz	2 kHz
01 (Default)	90 Hz	416 Hz	4 kHz
10	120 Hz	500 Hz	5 kHz
11	160 Hz	588 Hz	6 kHz

LS_SRS_SPACE**Loudspeaker SRS™ Surround Sound Space Effect**

Address (hex): 5Eh

Type: R/W

Bit 7	Bit 6	Bit 5	Bit 4	Bit 3	Bit 2	Bit 1	Bit 0
SRS_SPACE[7:0]							

Bit Name	Reset	Function																								
SRS_SPACE[7:0]	10000000	Defines the gain of the SRS™ Surround component (in linear scale).																								
		<table border="0"> <thead> <tr> <th></th> <th><u>Level (%)</u></th> <th></th> <th><u>Level (%)</u></th> </tr> </thead> <tbody> <tr> <td>1000 0000 (Default)</td> <td>100%</td> <td>0000 0100</td> <td>3.1%</td> </tr> <tr> <td>0111 1111</td> <td>99.2%</td> <td>0000 0011</td> <td>2.3%</td> </tr> <tr> <td>0111 1110</td> <td>98.4%</td> <td>0000 0010</td> <td>1.6%</td> </tr> <tr> <td>0111 1101</td> <td>97.6%</td> <td>0000 0001</td> <td>0.8%</td> </tr> <tr> <td>.....</td> <td></td> <td>0000 0000</td> <td>0%</td> </tr> </tbody> </table>		<u>Level (%)</u>		<u>Level (%)</u>	1000 0000 (Default)	100%	0000 0100	3.1%	0111 1111	99.2%	0000 0011	2.3%	0111 1110	98.4%	0000 0010	1.6%	0111 1101	97.6%	0000 0001	0.8%		0000 0000	0%
	<u>Level (%)</u>		<u>Level (%)</u>																							
1000 0000 (Default)	100%	0000 0100	3.1%																							
0111 1111	99.2%	0000 0011	2.3%																							
0111 1110	98.4%	0000 0010	1.6%																							
0111 1101	97.6%	0000 0001	0.8%																							
.....		0000 0000	0%																							

LS_SRS_CENTER Loudspeaker SRS™ Surround Sound Center Effect

Address (hex): 5Fh

Type: R/W

Bit 7	Bit 6	Bit 5	Bit 4	Bit 3	Bit 2	Bit 1	Bit 0
SRS_CENTER[7:0]							

Bit Name	Reset	Function			
SRS_CENTER [7:0]	10000000	Defines the gain of the SRS™ Center component (in linear scale).			
			<u>Level (%)</u>		<u>Level (%)</u>
		1000 0000 (Default)	100%	0000 0100	3.1%
		0111 1111	99.2%	0000 0011	2.3%
		0111 1110	98.4%	0000 0010	1.6%
		0111 1101	97.6%	0000 0001	0.8%
.....		0000 0000	0%		

9.14 5- Band Equalizer**LS_EQ_CTRL Loudspeaker Equalizer Control Register**

Address (hex): 60h

Type: R/W

Bit 7	Bit 6	Bit 5	Bit 4	Bit 3	Bit 2	Bit 1	Bit 0
EQ_ON	0	0	0	0	0	0	0

Bit Name	Reset	Function
EQ_ON	0	5-Band Equalizer Enable 0: 5-Band Equalizer is disabled 1: 5-Band Equalizer is enabled (Default)
Bits[6:0]	000000	Reserved.

LS_EQ_BAND[1:5] Loudspeaker Equalizer Gain

Address (hex): 61h to 65h

Type: R/W

Bit 7	Bit 6	Bit 5	Bit 4	Bit 3	Bit 2	Bit 1	Bit 0
0	0	0	EQ_BAND1_GAIN[4:0] (S)				
0	0	0	EQ_BAND2_GAIN[4:0] (S)				
0	0	0	EQ_BAND3_GAIN[4:0] (S)				
0	0	0	EQ_BAND4_GAIN[4:0] (S)				
0	0	0	EQ_BAND5_GAIN[4:0] (S)				

Bit Name	Reset	Function
Bits[7:5]	000	Reserved.
EQ_BAND1_GAIN[4:0]	00000	Band Gain Adjustment within a range from -12 dB to +12 dB in steps of 1 dB. BAND1 = Bass (Centered 100 Hz) BAND2 = Bass-Medium (Centered 330 Hz) BAND3 = Medium (Centered 1 kHz) BAND4 = Treble-Medium (Centered 3.3 kHz) BAND5 = Treble (Centered 6.6 kHz)
EQ_BAND2_GAIN[4:0]	00000	
EQ_BAND3_GAIN[4:0]	00000	
EQ_BAND4_GAIN[4:0]	00000	
EQ_BAND5_GAIN[4:0]	00000	

Table 25: Loudspeaker/Headphone Equalizer Gain Values

Value	Gain G (dB)
01100	+12
01011	+11
01010	+10
.....
00000 (Default)	0
.....
10110	-10
10101	-11
10100	-12

9.15 Loudness/Bass & Treble

LS_LOUD

Loudspeaker Loudness Control Register

Address (hex): 66h

Type: R/W

Bit 7	Bit 6	Bit 5	Bit 4	Bit 3	Bit 2	Bit 1	Bit 0
LOUD_ON	LOUD_TH[2:0]			LOUD_FREQ	LOUD_GHR[2:0]		

Bit Name	Reset	Function
LOUD_ON	0	Loudness Enable 0: Loudness disabled 1: Loudness enabled
LOUD_TH[2:0]	000	Loudness Threshold Programmable values are listed in Table 26 .
LOUD_FREQ	0	Bass Cut-off Frequency Select 0: 40 Hz bass cut-off frequency (Normal mode) 1: 120 Hz bass cut-off frequency (Bass Amplified mode)
LOUD_GHR[2:0]	010	Loudness Maximum Treble Gain Programmable values are listed in Table 26 .

Table 26: Loudness Control Values

Bitfield Value	Threshold (dB) LOUD_TH[2:0]	Max. Treble Gain (dB) LOUD_GHR[2:0]
000	0 (Default)	0
001	-6	3
010	-12	6 (Default)
011	-18	9
100	-24	12
101	-30	15
110	-36	18
111	-42	Reserved

HP_BT_CTRL

Headphone Bass/Treble Control

Address (hex): 71h

Type: R/W

Bit 7	Bit 6	Bit 5	Bit 4	Bit 3	Bit 2	Bit 1	Bit 0
BT_ON	0	0	0	0	0	0	0

Bit Name	Reset	Function
BT_ON	0	Headphone Bass/Treble Enable 0: Headphone Bass/Treble disabled 1: Headphone Bass/Treble enabled
Bit [6:0]	0	Reserved.

HP_BASS_GAIN Headphone Bass Gain

Address (hex): 72h

Type: R/W

Bit 7	Bit 6	Bit 5	Bit 4	Bit 3	Bit 2	Bit 1	Bit 0
0	0	0	BASS_GAIN[4:0]				

Bit Name	Reset	Function
Bits[7:5]	000	Reserved
BASS_GAIN[4:0]	00000	Gain Tuning of Headphone Bass Frequency Gain may be programmed within a range between +12 dB and -12 dB in steps of 1 dB. Programmable values are listed in Table 25 .

HP_TREBLE_GAIN Headphone Treble Gain

Address (hex): 73h

Type: R/W

Bit 7	Bit 6	Bit 5	Bit 4	Bit 3	Bit 2	Bit 1	Bit 0
0	0	0	TREBLE_GAIN[4:0]				

Bit Name	Reset	Function
Bits[7:5]	000	Reserved
TREBLE_GAIN [4:0]	00000	Gain Tuning of Headphone Treble Frequency Gain may be programmed within a range between +12 dB and -12 dB in steps of 1 dB. Programmable values are listed in Table 25 .

9.16 Volume/Balance Control Registers

LS_VOL_CTRL

Loudspeaker Volume Control Register

Address (hex): 67h

Type: R/W

Bit 7	Bit 6	Bit 5	Bit 4	Bit 3	Bit 2	Bit 1	Bit 0
0	0	0	0	0	0	0	BAL_MODE

Bit Name	Reset	Function
Bits[7:1]	000000	Reserved.
BAL_MODE	1	0: Independent mode. 1: Differential mode (Default)

HP_VOL_CTRL

Headphone Volume Control Register

Address (hex): 75h

Type: R/W

Bit 7	Bit 6	Bit 5	Bit 4	Bit 3	Bit 2	Bit 1	Bit 0
0	0	0	0	0	0	0	BAL_MODE

Bit Name	Reset	Function
Bits[7:1]	000000	Reserved.
BAL_MODE	1	0: Independent mode. 1: Differential mode (Default)

LS_CVOL LS_VOL_L

Loudspeaker Common Volume Control Register Loudspeaker Left Volume Control Register

Address (hex): 68h

Type: R/W

Bit 7	Bit 6	Bit 5	Bit 4	Bit 3	Bit 2	Bit 1	Bit 0
CVOL[7:0] / VOL_L[7:0]							

Bit Name	Reset	Function
CVOL[7:0]	00000000	Loudspeaker Common Volume Volume may be programmed within a range between 0 dB and -96 dB in steps of 0.375 dB. Programmable values are listed in Table 27 .

Bit Name	Reset	Function
VOL_L[7:0]	00000000	Loudspeaker Left Volume Volume may be programmed within a range between 0 dB and -96 dB in steps of 0.375 dB. Programmable values are listed in Table 27 .

HP_CVOL
HP_VOL_L

Headphone Common Volume Control Register
Headphone Left Volume Control Register

Address (hex): 76h

Type: R/W

Bit 7	Bit 6	Bit 5	Bit 4	Bit 3	Bit 2	Bit 1	Bit 0
CVOL[7:0] / VOL_L[7:0]							

Bit Name	Reset	Function
CVOL[7:0]	00000000	Headphone Common Volume Volume may be programmed within a range between 0 dB and -96 dB in steps of 0.375 dB. Programmable values are listed in Table 27 .
VOL_L[7:0]	00000000	Headphone Left Volume Volume may be programmed within a range between 0 dB and -96 dB in steps of 0.375 dB. Programmable values are listed in Table 27 .

Table 27: Common or Left Volume Control Values

Register Value	Volume Level (dB)
1111 1111	0 (1 V _{RMS})
1111 1110	-0.375
1111 1101	-0.75
.....
1000 0000 (Default)	-48
.....
0000 0010	-94.50
0000 0001	-95.25
0000 0000	-95.625

LS_BAL
LS_VOL_R
Loudspeaker Balance Control Register
Loudspeaker Right Volume Control Register

Address (hex): 69h

Type: R/W

Bit 7 Bit 6 Bit 5 Bit 4 Bit 3 Bit 2 Bit 1 Bit 0

BAL[7:0] / VOL_R[7:0]

Bit Name	Reset	Function
BAL[7:0]	00000000	Loudspeaker Differential Balance In Differential mode, the balance may be programmed in steps of 0.75 dB. Programmable values are listed in Table 28 .
VOL_R[7:0]	00000000	Loudspeaker Right Volume Control In Independent mode, the volume may be programmed within a range between 0 dB and -96 dB in steps of 0.375 dB. Programmable values are listed in Table 29 .

HP_BAL
HP_VOL_R
Headphone Balance Control Register
Headphone Right Volume Control Register

Address (hex): 77h

Type: R/W

Bit 7 Bit 6 Bit 5 Bit 4 Bit 3 Bit 2 Bit 1 Bit 0

BAL[7:0] / VOL_R[7:0]

Bit Name	Reset	Function
BAL[7:0]	00000000	Headphone Differential Balance In Differential mode, the balance may be programmed in steps of 0.75 dB. Programmable values are listed in Table 28 .
VOL_R[7:0]	00000000	Headphone Right Volume Control In Independent mode, the volume may be programmed within a range between 0 dB and -96 dB in steps of 0.375 dB. Programmable values are listed in Table 29 .

Table 28: Differential Balance Control Values

Register Value	Left/Common Level		Right/Common Level	
0111 1111 (7Fh)	-95.25 dB	0.78%	0 dB	100%
0111 1110	-94.50 dB	0.56%	0 dB	100%
0111 1101	-93.75 dB	2.34%	0 dB	100%
.....	
0000 0000 (Default)	0 dB	100%	0 dB	100%
.....	

Table 28: Differential Balance Control Values

Register Value	Left/Common Level		Right/Common Level	
1000 0010	0 dB	100%	-94.50 dB	1.56%
1000 0001	0 dB	100%	-95.25 dB	0.78%
1000 0000 (80h)	0 dB	100%	-96.00 dB	0.00%

Table 29: Right/Left Volume Control Values

Register Value	Volume Level (dB)
1111 1111	0 (1 V _{RMS})
1111 1110	-0.375
1111 1101	-0.75
.....
1000 0000 (Default)	-48
.....
0000 0010	-94.50
0000 0001	-95.25
0000 0000	-95.625

9.17 Subwoofer

SW_GAIN

Subwoofer Gain

Address (hex): 6Ah

Type: R/W

Bit 7 Bit 6 Bit 5 Bit 4 Bit 3 Bit 2 Bit 1 Bit 0

SW_GAIN[7:0]

Bit Name	Reset	Function
SW_GAIN[7:0]	10000000	Subwoofer Gain Gain may be programmed within a range between 0 dB and -96 dB in steps of 0.375 dB. Programmable values are listed in Table 27 .

BEEPER_TONE Beeper Tone Control

Address (hex): 7Ah

Type: R/W

Bit 7	Bit 6	Bit 5	Bit 4	Bit 3	Bit 2	Bit 1	Bit 0
BEEP_FREQ[2:0]				BEEP_VOL[4:0]			

Bit Name	Reset	Function
BEEP_FREQ[2:0]	011	Defines the frequency of the beeper tone from 62.5 Hz to 8 kHz in octaves 000: 62.5 Hz 100: 1 kHz 001: 125 Hz 101: 2 kHz 010: 250 Hz 110: 4 kHz 011: 500 Hz (Default) 111: 8 kHz
BEEP_VOL[4:0]	10000	Defines the Beeper volume from 0 to -93 dB in steps of 3 dB. 11111: 0 dB (1 V_{RMS}) ... 11110: -3 dB 00011: -84 dB 11101: -6 dB 00010: -87 dB ... 00001: -90 dB 10000: -48 dB (Default) 00000: -93 dB

10 Input/Output Groups

Pin numbers apply to SDIP package only.

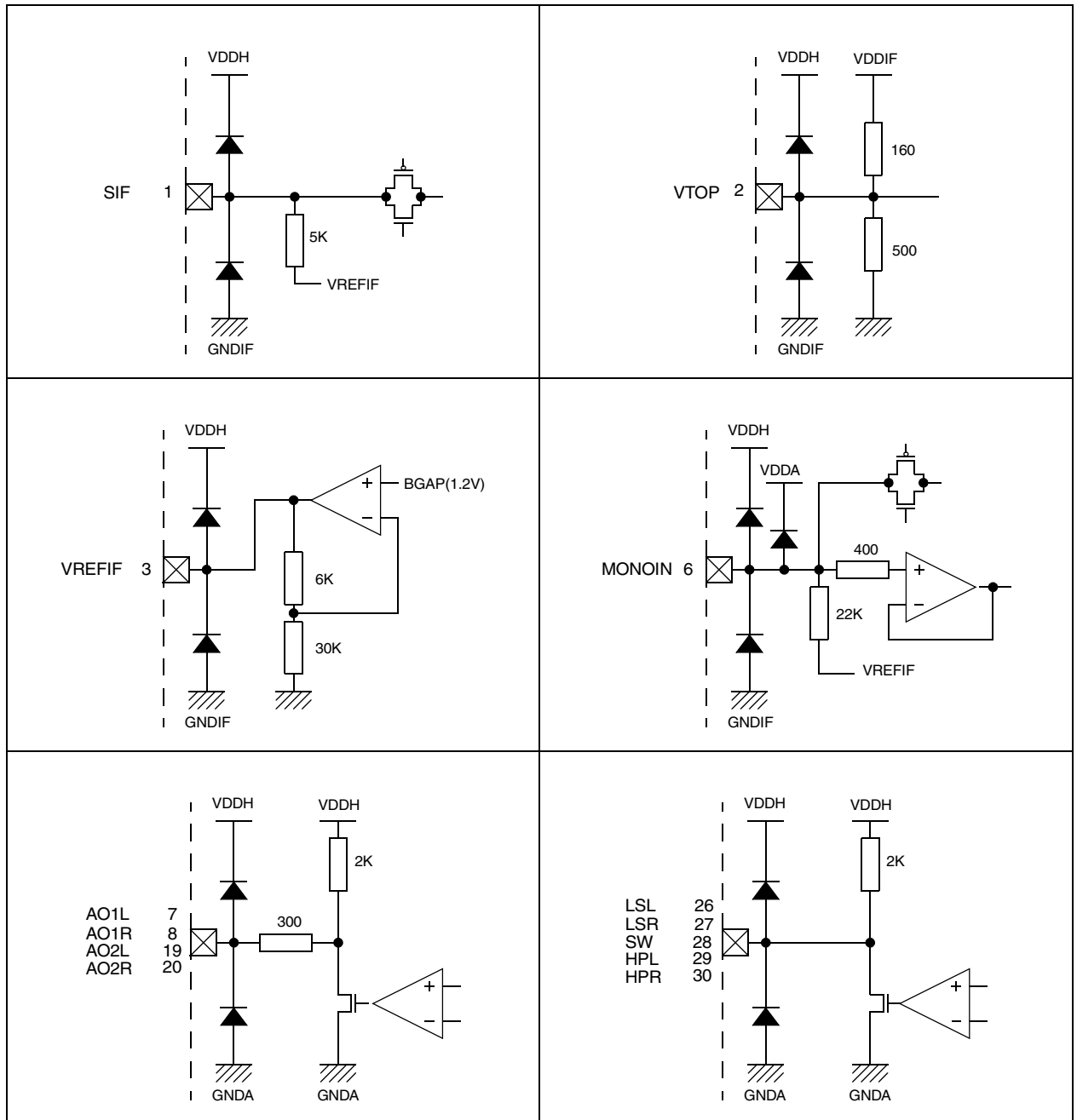

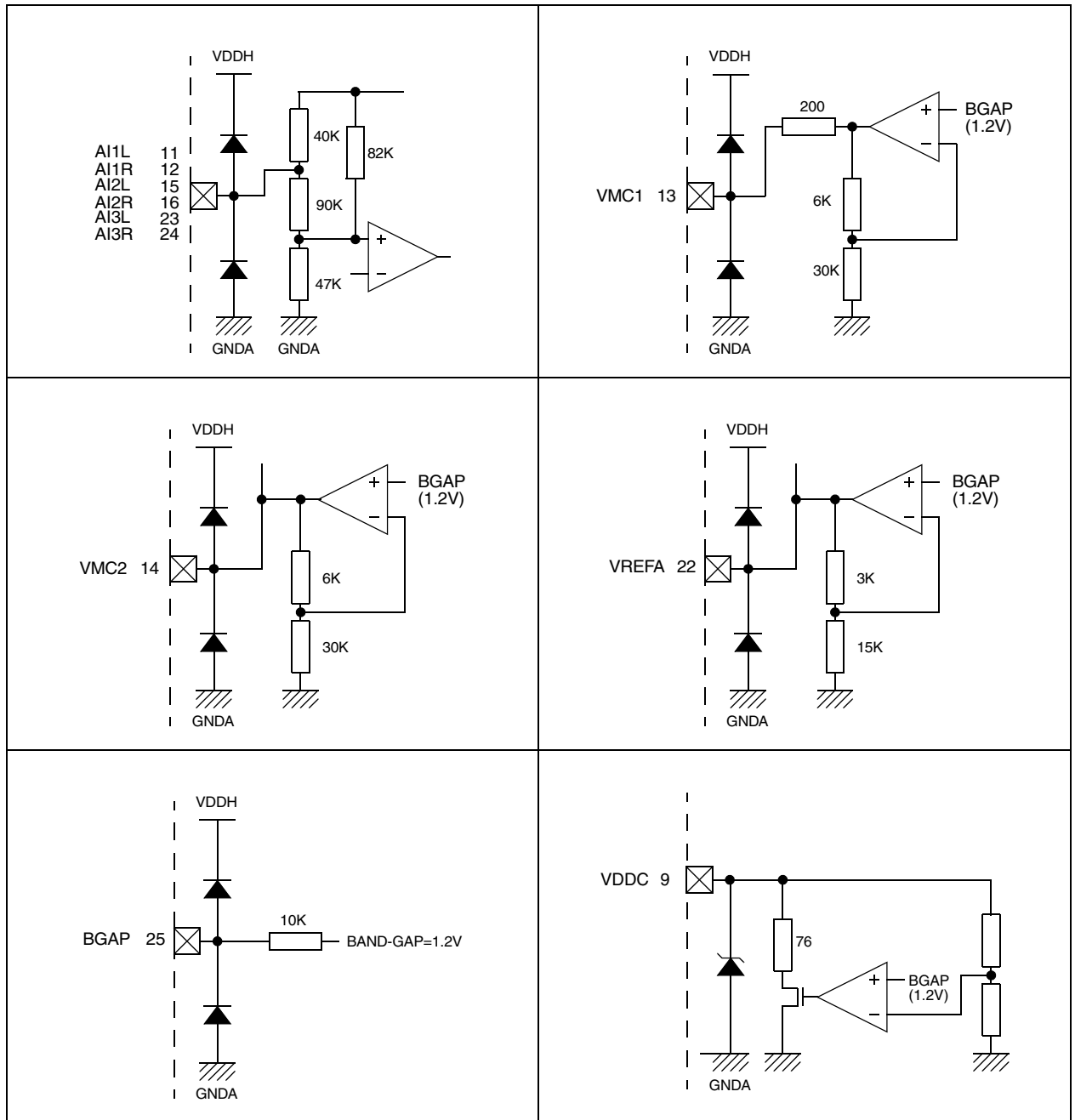

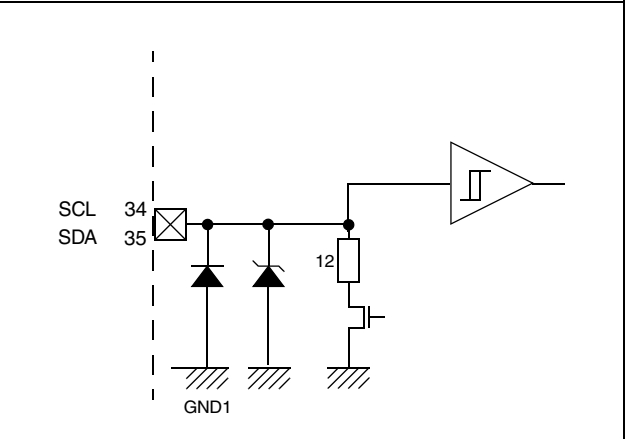
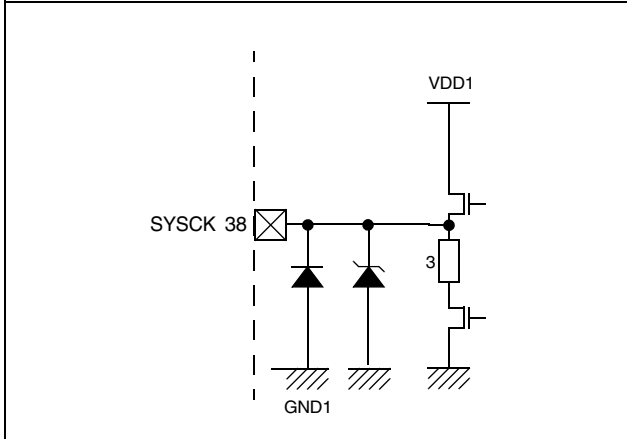
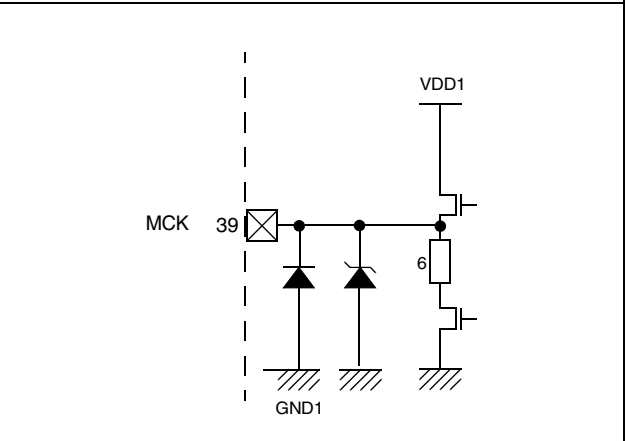
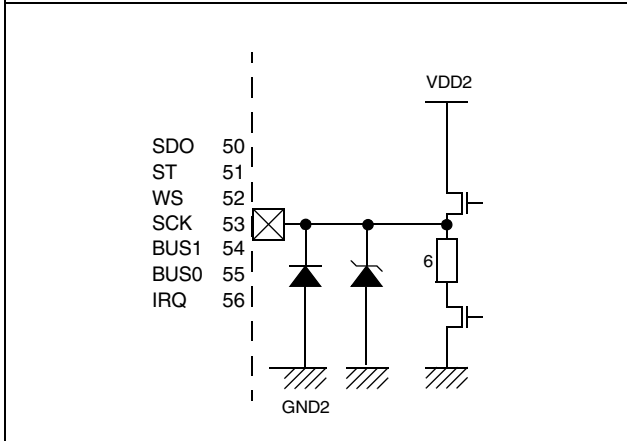
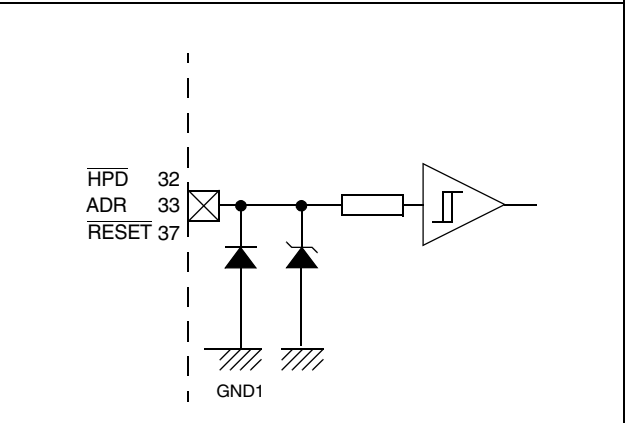
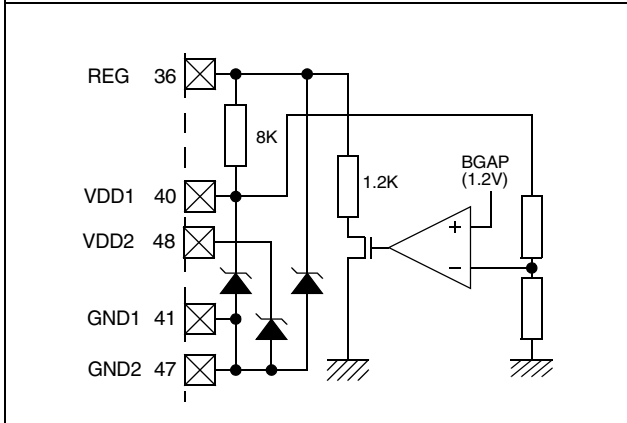
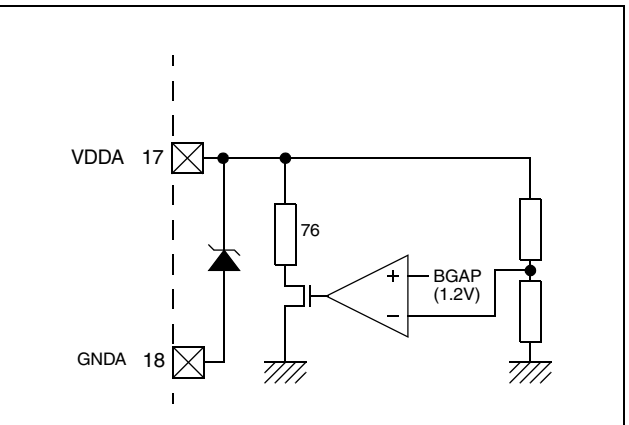
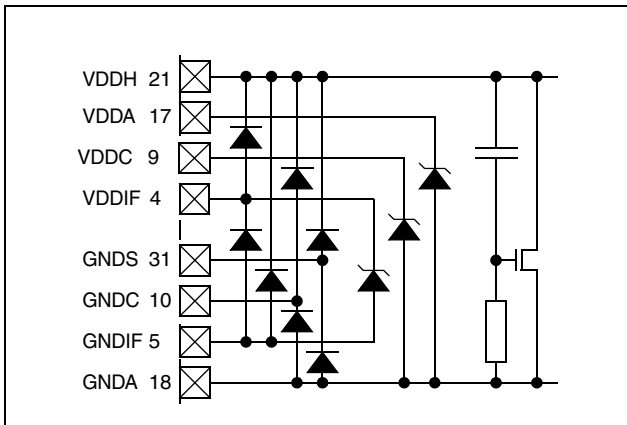

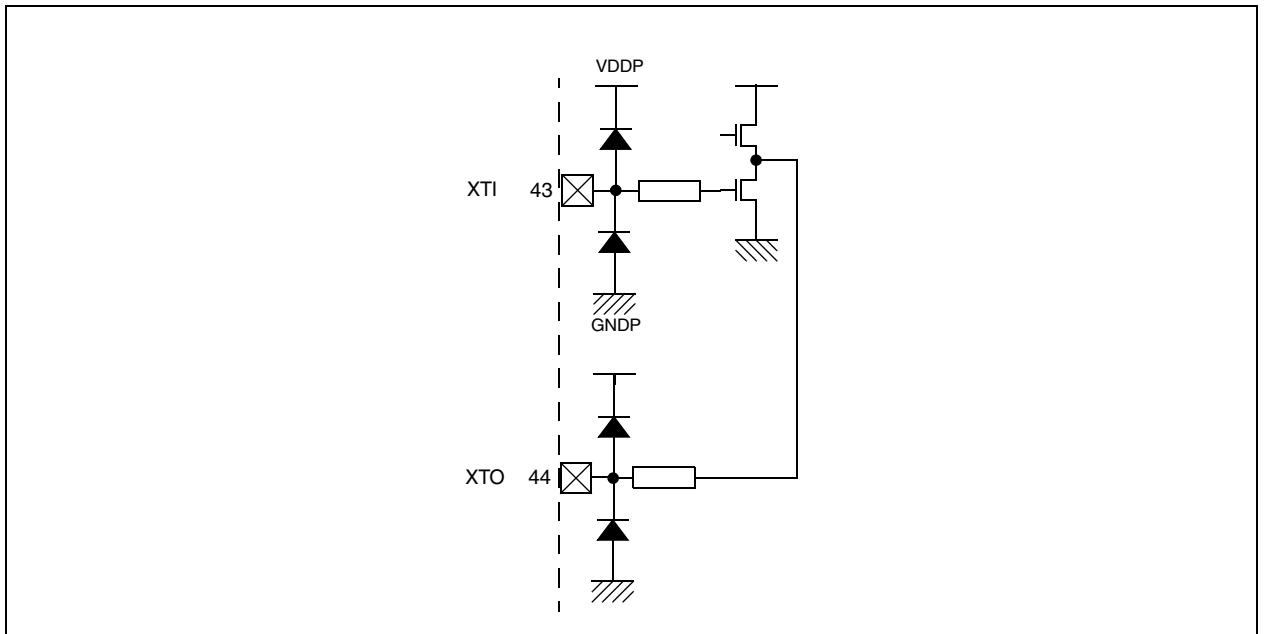

11 Electrical Characteristics

A 10 k Ω load is applied to all outputs.

11.1 Absolute Maximum Ratings

Symbol	Parameter	Value	Units
DV _{DD}	Digital Supply Voltage (V _{DD1} , V _{DD2} , V _{DDP})	4.6	V
HV _{DD}	Analog Supply High Voltage (V _{DDH})	9.5	V
V _{ESD}	Capacitor 100 pF discharged via 1.5 k Ω serial resistor (Human Body Model)	± 4	kV
T _{OPER}	Operating Ambient Temperature	0, +70	$^{\circ}$ C
T _{STG}	Storage Temperature	-55 to +150	$^{\circ}$ C

Note: Analog supply voltages (V_{DDIF}, V_{DDC} and V_{DDA}) are regulated by internal circuits. For more information, refer to [Section 7.1: Supply Voltages](#).

11.2 Thermal Data

Symbol	Parameter	Value	Units
R _{thJA}	Junction-to-Ambient Thermal Resistance	SDIP56 TQFP80	40 42 $^{\circ}$ C/W

11.3 Supply

Test Conditions: T_{OPER} = 25 $^{\circ}$ C, V_{DDH} = 8 V, V_{DDA} is supplied by 8 V via 330 Ω , V_{DDIF} is connected to V_{DDC} and is supplied by 5 V via 22 Ω and DV_{DD} (V_{DD1}, V_{DD2} and V_{DDP}) is supplied by 5 V via an external ballast transistor. For more information, refer to [Figure 4 on page 7](#).

Symbol	Parameter	Test Conditions	Min.	Typ.	Max.	Units
DV _{DD}	Digital Supply Voltage (V _{DD1} , V _{DD2} , V _{DDP})		3.0	3.3	3.6	V
HV _{DD}	Analog Supply High Voltage (V _{DDH})		7.6	8.0	8.4	V
AV _{DD}	Analog Supply Voltage (V _{DDIF} , V _{DDC} , V _{DDA})		3.0	3.3	3.6	V
I _{VDD}	V _{DD} Current Consumption (V _{DD1} , V _{DD2} , V _{DDP})		130	160	190	mA
I _{VDDIF} I _{VDDC}	V _{DDIF} Current Consumption (V _{DDIF} , V _{DDC})		60	75	85	mA
I _{VDDA}	V _{DDA} Current Consumption		7	12	18	mA
I _{VDDH}	V _{DDH} Current Consumption	5.0 V		15		mA
		8.0 V	15	25	35	

11.4 Crystal Recommendations

Symbol	Parameter	Min.	Typ.	Max.	Units
F_P	Crystal Parallel Resonance Frequency (at 22 pF load capacitor)		27		MHz
DF/F_P	Frequency Tolerance at 25 °C	-50		+50	ppm
DF/F_T	Frequency Stability versus Temperature within a range from 0 to 70 °C	-50		+50	ppm
C_1	Motional Capacitor	8			fF
R_S	Serial Resistance			50	Ω
C_S	Shunt Capacitance			7	pF

11.5 Analog Sound IF Signal Recommendations

Symbol	Parameter	Test Conditions	Min.	Typ.	Max.	Units
F_{SIF}	SIF Carrier Frequency		4		8	MHz
R_{INSIF}	SIF Input Resistance		4.5	6	7.5	k Ω
DC_{INSIF}	SIF Input DC Level			1.47		V
C_{INSIF}	SIF Input Capacitance				15	pF
FM Carrier						
$VSIF_{FM}$	SIF Input Level for FM Carrier		0.02		1.6	V_{PP}
DEV_{FM}	FM Deviation	FM50k (Standard)	± 15	± 50	± 125	kHz
		FM200k (DK only)		± 200		
		FM350k (DK only)		± 350		
		FM500k (DK mono only)		± 500		
$DFSIF_{FM}$	SIF Carrier Accuracy for FM	Standard (FM50k)		± 1	± 5	kHz
		Shifted Standard (FM50k with DCO compensation)			± 120	kHz
$R_{FM1/FM2}$	Carrier Ratio FM1/FM2 for A2 System			7		dB
$R_{FM/QPSK}$	Carrier Ratio FM/QPSK for NICAM System			13		dB
AM Carrier						
$VSIF_{AM}$	SIF Input Level for AM Carrier (Unmodulated)		0.04		0.8	V_{PP}
DEV_{AM}	Modulation Depth for AM		0		100	%
$DFSIF_{AM}$	SIF Carrier Accuracy for AM			± 1	± 5	kHz
$R_{AM/QPSK}$	AM/QPSK Carrier Ratio for NICAM System			17		dB

11.6 SIF to LS/HP/SCART Path Characteristics

Symbol	Parameter	Test Conditions	Min.	Typ.	Max.	Units
FM Demodulation						
BAND _{FM}	Frequency Response	20Hz - 15kHz	-1.5		+1.5	dB
SNR _{FM}	Signal to Noise	RMS unweighted, 20Hz-15kHz, Standard B/G 50 kHz FM Deviation, 1kHz LS Output 0.7 V _{RMS}		70		dB
THD _{FM}	Total Harmonic Distortion				0.1	%
SEP _{FM}	Stereo Channel Separation	RMS Standard B/G stereo A2, 50 kHz FM deviation, 1 kHz		45		dB
XTALK _{FM}	Dual Channel Crosstalk	RMS Standard B/G dual mono A2, 50 kHz FM deviation, 1 kHz		80		dB
NICAM Demodulation						
BAND _{NIC}	Frequency Response	20Hz - 15kHz	-1.0		+1.0	dB
SNR _{NIC}	Signal to Noise	RMS unweighted, 20Hz-15kHz, Standard B/G mono NICAM, 1 kHz LS Output 0.7 V _{RMS}		72		dB
THD _{NIC}	Total Harmonic Distortion				0.1	%
SEP _{NIC}	Stereo Channel Separation	RMS Standard B/G stereo NICAM, 1 kHz		80		dB
XTALK _{NIC}	Dual Channel Crosstalk	RMS Standard B/G dual mono NICAM, 1 kHz		80		dB
AM Demodulation						
BAND _{AM}	Frequency Response	20 Hz - 15 kHz	-1.0		+1.0	dB
SNR _{AM}	Signal to Noise	RMS unweighted 2 0Hz-15 kHz, Standard L, 54% AM Depth, 1 kHz LS Output 0.7 V _{RMS}		50		dB
THD _{AM}	Total Harmonic Distortion				0.6	%

11.7 SCART to SCART Analog Path Characteristics

Symbol	Parameter	Test Conditions	Min.	Typ.	Max.	Units
Analog-to-Analog (Through mode)						
R _{INSCART}	SCART Input Resistance		24	30	40	kΩ
R _{OUTSCART}	Output Resistance for SCARTs		250	300	450	Ω
VDC _{INSCART}	SCART Input DC Level			2.55		V
VDC _{OUTSCART}	SCART Output DC Level	VDDH = 5 V VDDH = 8 V		2.20 3.40		V
Clipping	THD	V _{IN} = 2 V _{RMS} at 1 kHz for VDDH = 8 V		0.1	0.5	%
THD	Total Harmonic Distortion	V _{IN} = 1.00 V _{RMS} at 1 kHz for VDDH = 5 V V _{IN} = 1.75 V _{RMS} at 1 kHz for VDDH = 8 V		0.0125 0.0125	0.03 0.05	%

Symbol	Parameter	Test Conditions	Min.	Typ.	Max.	Units
SNR	Signal to Noise Ratio	20 to 20 kHz Bandwidth, RMS unweighted $V_{IN} = 1.00 V_{RMS}$ for $VDDH = 5 V$ $V_{IN} = 1.75 V_{RMS}$ for $VDDH = 8 V$	75 80	85 90		dB
BAND	Frequency Response	20 Hz to 20 kHz	-0.5		0.5	dB
XTALK _{L/R}	Left/Right Crosstalk	1.4 V_{RMS} @ 1 kHz on ref signal, the other one grounded	70	75		dB
XTALK _{IN1/2}	Audio Crosstalk from Input Channel 1 to Input Channel 2	1.4 V_{RMS} @ 1 kHz on ref signal, all other inputs grounded	80	85		dB
XTALK _{OUT1/2}	Audio Crosstalk from Output Channel 1 to Output Channel 2	1.4 V_{RMS} @ 1 kHz on reference output, signal on a single input, all other inputs grounded	80	85		dB

11.8 SCART to I2S Output Path (via ADC) Characteristics

Symbol	Parameter	Test Conditions	Min.	Typ.	Max.	Units
Clipping	THD	$V_{IN} = 1 V_{RMS}$ at 1 kHz for $VDDH = 5 V$ $V_{IN} = 2 V_{RMS}$ at 1 kHz for $VDDH = 8 V$		0.5 0.2	2.0 2.0	%
THD	Total Harmonic Distortion	$V_{IN} = 0.90 V_{RMS}$ at 1 kHz for $VDDH = 5 V$ $V_{IN} = 1.75 V_{RMS}$ at 1 kHz for $VDDH = 8 V$		0.03 0.03	0.05 0.05	%
SNR	Signal to Noise Ratio	20 to 15 kHz Bandwidth, RMS unweighted $V_{IN} = 0.90 V_{RMS}$ for $VDDH = 5 V$ $V_{IN} = 1.75 V_{RMS}$ for $VDDH = 8 V$	70 70	74 74		dB
BAND	Frequency Response	20 Hz to 15 kHz	-0.5		0.5	dB

11.9 MONOIN to ADC and I2S Output Path Characteristics

Symbol	Parameter	Test Conditions	Min.	Typ.	Max.	Units
$R_{INMONOIN}$	MONO Input Resistance		15	22	30	k Ω
$VDC_{INMONOIN}$	MONO Input DC Level			1.45		V
THD	Total Harmonic Distortion	$V_{IN} = 0.45 V_{RMS}$ at 1 kHz		0.03	0.05	%
SNR	Signal to Noise Ratio	20 to 15 kHz Bandwidth, RMS unweighted $V_{IN} = 0.45 V_{RMS}$	70	74		dB
BAND	Frequency Response	20 Hz to 15 kHz	-0.5		0.5	dB

11.10 I2S to LS/HP/SW Path Characteristics

Symbol	Parameter	Test Conditions	Min.	Typ.	Max.	Units
$R_{OUTMAIN}$	Output Resistance for Main Outputs	L _{SL} , L _{SR} , SW, H _{PL} and H _{PR} pins		5	30	Ω
$VDC_{OUTMAIN}$	MAIN Output DC Level			2.20		V

Symbol	Parameter	Test Conditions	Min.	Typ.	Max.	Units
THD	Total Harmonic Distortion	90% Full-scale Range at 1 kHz		0.025	0.050	%
SNR	Signal to Noise Ratio	20 to 15 kHz Bandwidth, RMS unweighted, 90% Full-scale Range	72	76		dB
V _{OUTAMP}	MAIN Output Amplitude	90% Full-scale Range at 1 kHz	0.800	0.875	0.950	V _{RMS}

11.11 I2S to SCART Path Characteristics

Symbol	Parameter	Test Conditions	Min.	Typ.	Max.	Units
THD	Total Harmonic Distortion	90% Full-scale Range at 1 kHz		0.025	0.100	%
SNR	Signal to Noise Ratio	20 Hz to 15 kHz Bandwidth unweighted, 90% Full-scale Range	72	76		dB
V _{OUTAMP}	MAIN Output Amplitude	90% Full-scale Range at 1 kHz, VDDH = 8V	1.60	1.75	1.90	V _{RMS}

11.12 Loudspeaker and Headphone Volume Control Characteristics

Symbol	Parameter	Test Conditions	Min.	Typ.	Max.	Units
VOL_MIN	Maximum Attenuation	I2S to DAC at 1 kHz with 1 active channel	82	90		dB
VOL_DNL	Maximum Non-Linearity Step to Step	Volume Control Range of 0 dB to 72 dB		0.1	0.3	dB

11.13 MUTE Performance

Symbol	Parameter	Test Conditions	Min.	Typ.	Max.	Units
	DAC Mute	I2S to DAC at 1 kHz with 1 active channel	85	95		
	SCART Mute	1.4 V _{RMS} @ 1 kHz on ref signal, all other inputs grounded	78	81		

11.14 Digital I/Os

Symbol	Parameter	Test Conditions	Min.	Typ.	Max.	Units
V _{IL}	Low Level Input Voltage				0.5	V
V _{IH}	High Level Input Voltage		2.0			V
I _{IN}	Input Current				1	μA

11.15 I²C Bus Interface

Symbol	Parameter	Min.	Typ.	Max.	Units
SCL					
V _{IL}	Input Voltage Low Level	0		0.7	V
V _{IH}	Input Voltage High Level	3		V _{DD}	V
V _{OL}	Low Output Voltage (I _{OL} = 3 mA)	0		0.8	V
f _{SCL}	SCL Clock Frequency			400	kHz
t _r , t _f	Input Rise/Fall Times (10 to 90%)			0.8	μs
I _{I(L)}	Input Leakage Current (V _i = 5.5 V)			10	μA
C _i	Input Capacitance			10	pF
SDA					
V _{IL}	Input Voltage Low Level	0		0.7	V
V _{IH}	Input Voltage High Level	3		V _{DD}	V
t _r , t _f	Input Rise/Fall Times (10 to 90%)			0.8	μs
I _{I(L)}	Input Leakage Current (V _i = 5.5 V with Output Off)			10	μA
V _{OL}	Low Output Voltage (I _{OL} = 3 mA)	0		0.8	V
t _{fo}	Output Fall Time between 3 V and 1 V			0.6	μs
C _L	Load Capacitance			400	pF
I _{ACK}	Maximum Sink Current			3	mA
TIMING					
t _{LOW}	Low Period	1			μs
t _{HIGH}	High Period	1			μs
t _{SU, DAT}	Data Setup Time	250			ns
t _{HD, DAT}	Data Hold Time	250			ns
t _{SU, STOP}	Stop Setup Time from Clock High		1		μs
t _{BUF}	Start Setup Time following a Stop		1		μs
t _{HD, STA}	Start Hold Time		1		μs
t _{SU, STA}	Start Setup Time following Clock Low to High Transition		1		μs

Figure 19: Serial Bus Timing

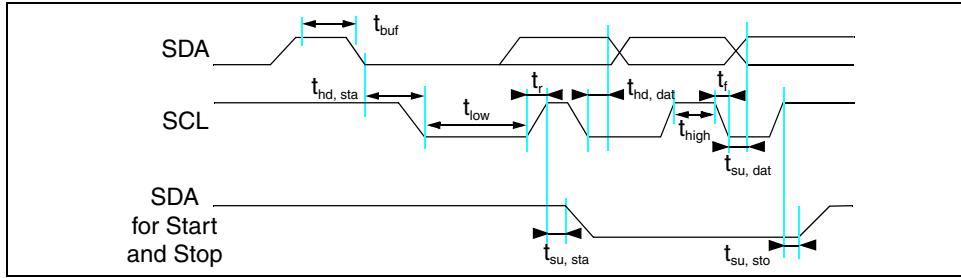

12 Package Mechanical Data

Figure 20: 56-Pin Shrink Plastic Dual In Line Package, 600-mil Width

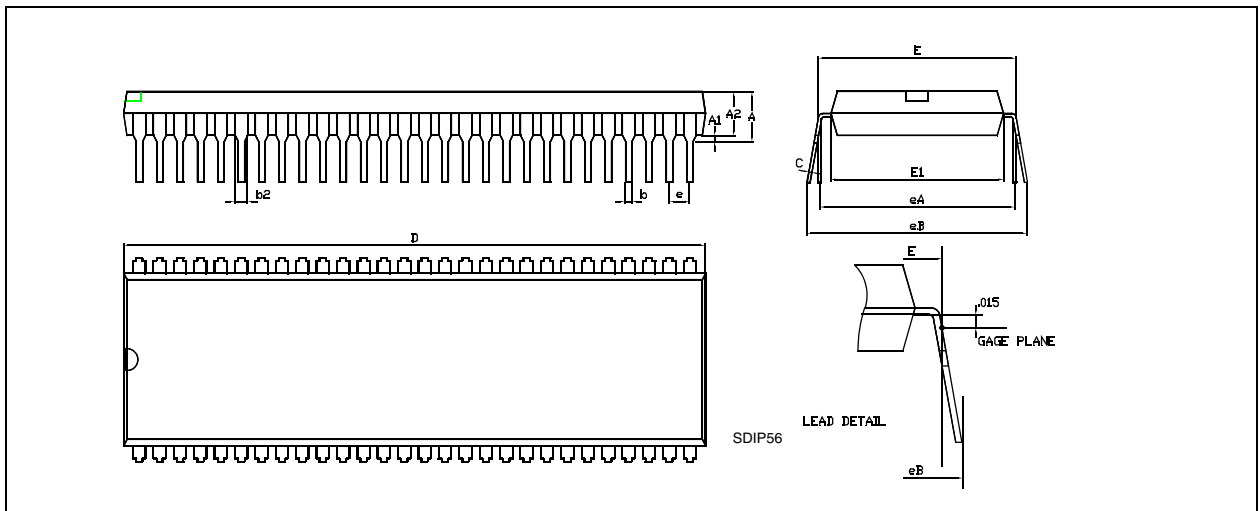

Dim.	mm			inches		
A			6.35			0.250
A1	0.38			0.015		
A2	3.18		4.95	0.125		0.195
b		0.41			0.016	
b2		0.89			0.035	
C	0.20		0.38	0.008		0.015
D	50.29		53.21	1.980		2.095
E		15.01			0.591	
E1	12.32		14.73	0.485		0.580
e		1.78			0.070	
eA		15.24			0.600	
eB			17.78			0.700
L	2.92		5.08	0.115		0.200

Figure 21: 80-Pin Thin Plastic Quad Flat Package

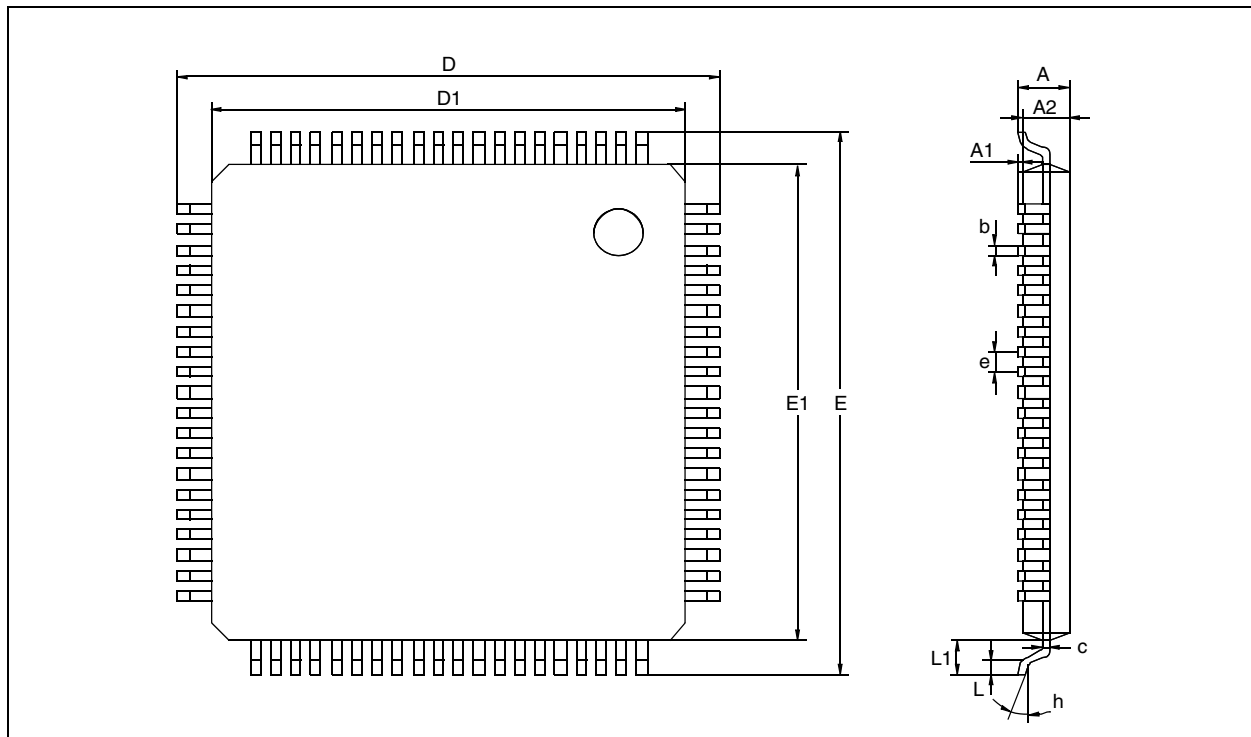

Dim.	mm			inches		
	Min.	Typ.	Max.	Min.	Typ.	Max.
A			1.60			0.063
A1	0.05		0.15	0.002		0.006
A2	1.35	1.40	1.45	0.053	0.055	0.057
b	0.22	0.32	0.38	0.009	0.013	0.015
C	0.09		0.20	0.004		0.008
D		16.00			0.630	
D1		14.00			0.551	
E		16.00			0.630	
E1		14.00			0.551	
e		0.65			0.026	
K	0°	3.5°	0.75°	0°	3.5°	0.75°
L	0.45	0.60	0.75	0.018	0.024	0.030
L1		1.00			0.039	

13 Revision History

Date	Revision	Modification
10 Jan 2003	2.0	First Release
7 May 2003	2.1	Modification to Table 6: Volume/Balance Control Registers on page 21 .
14 May 2004	2.2	Addition of pin 12 (TQFP80) to Table 2 . Updated Figure 6 .
25 Feb 2005	3	Modification of CETH (20h) register recommended value.

Index

A

Analog Power Supply	29
Analog-to-Digital Conversion	12
Automatic Frequency Control	14
Automatic Gain Control	12
Automatic Overmodulation Detection	13
Automatic Standard Recognition System 12-13, 33	

B

Balance Control	20
Bass Control	19
Beeper	22

C

Clock	16
Clock System Output	28

D

Digital Power Supply	29
Digital Stereo Output	28

H

Headphone Detection Mode	21
--------------------------------	----

I

I2C Address	31
I2S	28
Independent Mute Control	21
Input Audio Matrixing	26

L

Loudness Control	22
------------------------	----

M

Mute Control	21
--------------------	----

O

Output Audio Matrixing	26
------------------------------	----

P

Peak Detector	13
Peak Level Detector	26
Philips Mode	28
Power Supplies	29

S

Signal to Noise	88
Smart Volume Control	18
Sony Mode	28
Sound IF Signal	12
SRS 3D Surround	23
ST Wide Surround	19
Stereo Flag	27
Supply Voltages	29

T

Total Harmonic Distortion	88
Treble Control	19

V

Voltage Regulator	29
Volume Control	20

W

Word Selection Polarity	28
-------------------------------	----

Information furnished is believed to be accurate and reliable. However, STMicroelectronics assumes no responsibility for the consequences of use of such information nor for any infringement of patents or other rights of third parties which may result from its use. No license is granted by implication or otherwise under any patent or patent rights of STMicroelectronics. Specifications mentioned in this publication are subject to change without notice. This publication supersedes and replaces all information previously supplied. STMicroelectronics products are not authorized for use as critical components in life support devices or systems without express written approval of STMicroelectronics.

The ST logo is a registered trademark of STMicroelectronics
All other names are the property of their respective owners

© 2005 STMicroelectronics - All rights reserved

STMicroelectronics GROUP OF COMPANIES

Australia - Belgium - Brazil - Canada - China - Czech Republic - Finland - France - Germany - Hong Kong - India - Israel - Italy
- Japan - Malaysia - Malta - Morocco - Singapore - Spain - Sweden - Switzerland - United Kingdom - United States

www.st.com